



# 21 inch LCD Module Series

## **GHT210HDP33**

Dalian Good Display Co., Ltd





---

## Contents

No	ITEM	Page
	REVISIONS HISTORY	2
	CONTENTS	3
1	GENERAL DESCRIPTION	4
	1.1 Introduction	
	1.2 Features	
	1.3 Applications	
	1.4 General Specification	
2	ABSOLUTE MAXIMUM RATINGS	6
3	ELECTRICAL SPECIFICATIONS	7
	3.1 TFT LCD Open Cell	
4	INTERFACE CONNECTION	9
	4.1 Open Cell Input Signal & Power	
	4.2 LVDS Interface	
	4.3 LVDS Rx Interface Timing Parameter	
	4.4 LVDS Rx Interface Eye Diagram	
	4.5 LVDS Receiver Differential Input	
5	SIGNAL TIMING SPECIFICATIONS	15
	5.1 Timing Parameters (DE only mode)	
	5.2 Signal Timing Waveform	
	5.3 Input Signals, Basic Display Colors and Gray Scale of Colors	
	5.4 Power Sequence	
6	OPTICAL SPECIFICATIONS	19
7	MECHANICAL CHARACTERISTICS	21
8	RELIABILITY TEST	22
9	PACKING INFORMATION	23
10	HANDING & CAUTIONS	24
11	APPENDIX	25

## 1.0 GENERAL DESCRIPTION

### 1.1 Introduction

GHT210HDP33 is a color active matrix TFT LCD MDL using amorphous silicon TFT's (Thin Film Transistors) as an active switching devices. This MDL has a 20.9 inch diagonally measured active area with FHD resolutions (1920 horizontal by 132 vertical pixel array). Each pixel is divided into RED, GREEN, BLUE dots which are arranged in vertical stripe and this module can display 16.7M colors. The TFT-LCD MDL panel is adapted for a low reflection and higher color type.

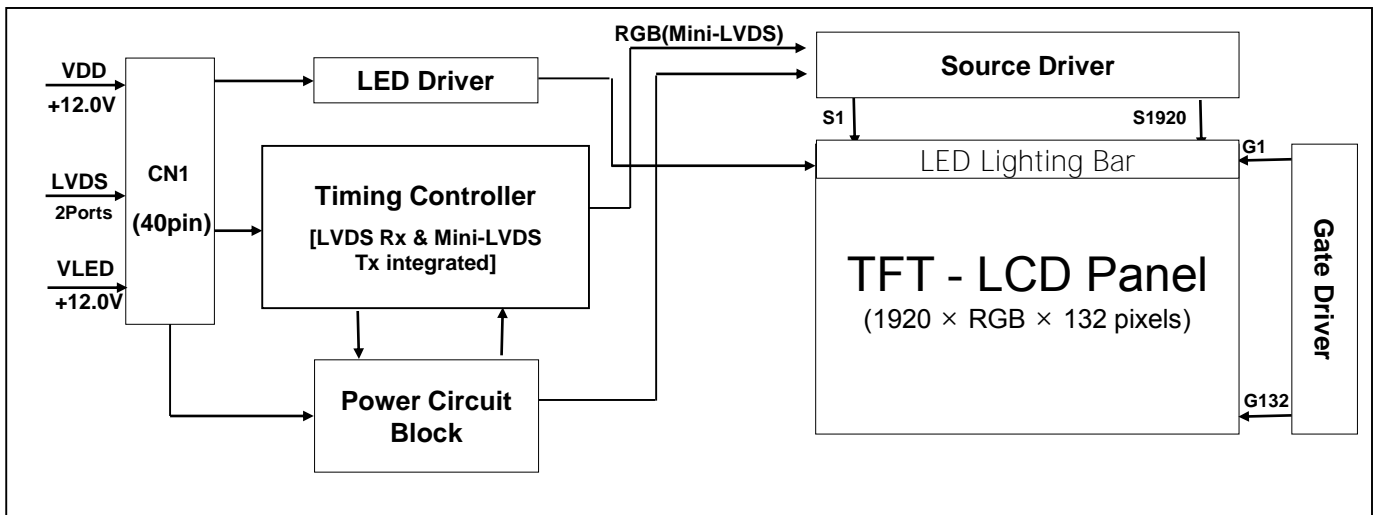

### 1.2 Features

- LVDS interface with 2 pixel / clock
- High-speed response
- Low color shift image quality
- 8-bit color depth, display 16.7M colors
- Wide viewing angle
- DE (Data Enable) only mode
- HADS technology is applied for high display quality
- RoHS compliant

### 1.3 Application

- Home Alone Multimedia TFT-LCD TV
- Display Terminals for Control System
- Full High Definition TV(FHD TV)
- AV application Products

### 1.4 General Specification

< Table 1. General Specifications >

Parameter	Specification	Unit	Remarks
Active area	529.416(H) × 36.39735(V)	mm	
Number of pixels	1920(H) × 132(V)	pixels	
Pixel pitch	91.9125(H) × 275.7375(V)	mm	
Pixel arrangement	Pixels RGB Vertical stripe		
Display colors	16.7M	colors	8bits True
Display mode	Normally Black		
Open Cell Transmittance	5.15 (Typ.)	%	At center point with BOE BLU
Dimensional outline	542.4(H) × 54.7(V) × 8.0(B) .	mm	Detail refer to drawing
Weight	505	g	
Power Consumption	7	Watt	Typ.
Bezel width (L/R/U/D)	6/6/11.3/6	mm	
Surface Treatment	Haze 25%		
Back-light	Up edge side, 1- LED Light bar		

## 2.0 ABSOLUTE MAXIMUM RATINGS

The followings are maximum values which, if exceed, may cause faulty operation or damage to the unit. The operational and non-operational maximum voltage and current values are listed in Table 2.

< Table 2. Open Cell Electrical Specifications >

[VSS=GND=0V]

Parameter	Symbol	Min.	Max.	Unit	Remark
Power Supply Voltage	VDD	VSS-0.3	13.5	V	Ta = 25 °C
Operating Temperature	T <sub>OP</sub>	0	+50	°C	Note 1
Storage Temperature	T <sub>SUR</sub>	-20	+60	°C	
	T <sub>ST</sub>	-20	+60	°C	
Operating Ambient Humidity	Hop	10	80	%RH	
Storage Humidity	Hst	10	80	%RH	

Note 1 : Temperature and relative humidity range are shown in the figure below.  
 Wet bulb temperature should be 39 °C max. and no condensation of water.

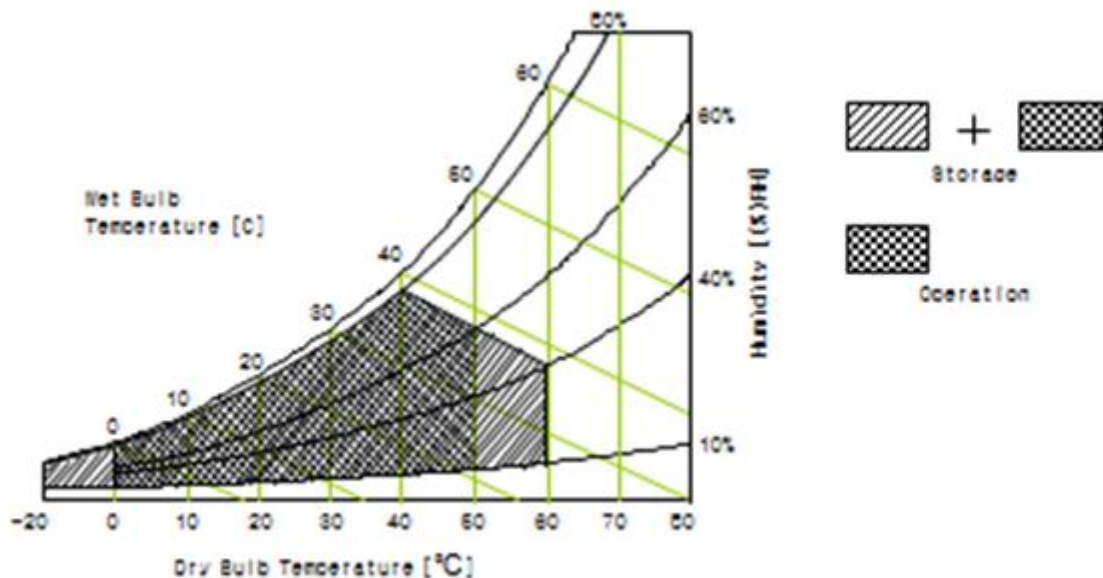

### 3.0 ELECTRICAL SPECIFICATIONS

#### 3.1 TFT LCD Open Cell

< Table 3. Open Cell Electrical Specifications >

[Ta =25 ± 2 °C]

Parameter		Symbol	Values			Unit	Remark
			Min	Typ	Max		
Power Supply Input Voltage		VDD	10.8	12	13.2	Vdc	
Power Supply Ripple Voltage		VRP			300	mV	
Power Supply Current		IDD	-	250	500	mA	Note 1
Power Consumption		PDD	-	3	6	Watt	
Rush current		IRUSH	-	-	3.0	A	Note 2
LVDS Interface	Differential Input High Threshold Voltage	VLVTH	+100		+300	mV	
	Differential Input Low Threshold Voltage	VLVTL	-300		-100	mV	
	Common Input Voltage	VLVC	1.0	1.2	1.4	V	
CMOS Interface	Input High Threshold Voltage	VIH	2.7	-	3.3	V	
	Input Low Threshold Voltage	VIL	0	-	0.6	V	

Note 1 : The supply voltage is measured and specified at the interface connector of LCM.

The current draw and power consumption specified is for VDD=12.0V,

Frame rate  $f_v=60\text{Hz}$  and Clock frequency = 74.25MHz.

Test Pattern of power supply current

a) Typ : Mosaic 7X5 (L0/L255)

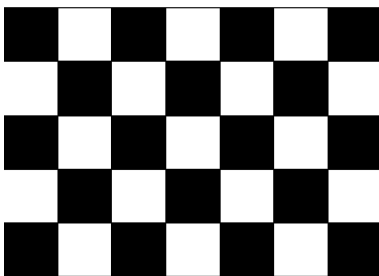

b) Max : Horizontal 1 Line (L0/L255)

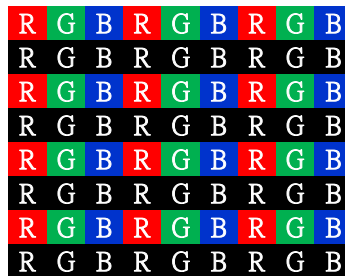

c) Flicker Pattern

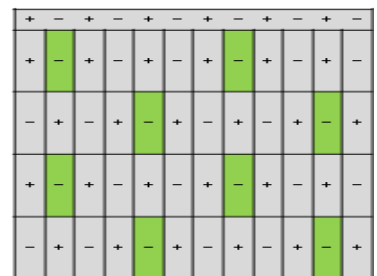

Note 2 : The duration of rush current is about 2ms and rising time of Power Input is 1ms(min)

### 3.0 ELECTRICAL SPECIFICATIONS

#### 3.2 Backlight Unit

< Table 3. Backlight Unit Electrical Specifications >

[Ta = 25 ± 2 °C]

Parameter		Min.	Typ.	Max.	Unit	Remarks
LED Forward Voltage	$V_F$	-	-	3.2	V	-
LED Forward Current	$I_F$	-	14		mA	-
LED Power Consumption	$P_{LED}$		4	-	W	Note 1
LED Life-Time	N/A	30000	-	-	Hour	IF = 14mA
Power supply voltage for LED Driver	VLED	5	12	21	V	
EN Control Level	Backlight on	2.1	3.3	5.0	V	
	Backlight off	0	-	0.8	V	
PWM Control Level	PWM High Level	2.1	3.3	5.0	V	
	PWM Low Level	0	-	0.6	V	
PWM Control Frequency	$F_{PWM}$	100	-	10,000	Hz	
Duty Ratio	-	1	-	100	%	

Notes : 1. Power supply voltage 12V for LED Driver, Driver efficiency 87%,

Calculator Value for reference  $I_F \times V_F \times 77 / 0.87 = P_{LED}$

2. The LED Life-time define as the estimated time to 50% degradation of initial luminous.



## 4.0 INTERFACE CONNECTION

### 4.1 Open Cell Input Signal & Power

- LVDS Connector : MSAK24025P40 (STM) or IS050-L40B-C10(UJU).

< Table 4. Open Cell Input Connector Pin Configuration >

Pin No	Symbol	Description	Pin No	Symbol	Description
1	RX00-	Negative Transmission data of Pixel 0 (ODD)	16	RXE1+	Positive Transmission data of Pixel 1 (EVEN)
2	RX00+	Positive Transmission data of Pixel 0 (ODD)	17	GND	Power Ground
3	RX01-	Negative Transmission data of Pixel 1 (ODD)	18	RXE2-	Negative Transmission data of Pixel 2 (EVEN)
4	RX01+	Positive Transmission data of Pixel 1 (ODD)	19	RXE2+	Positive Transmission data of Pixel 2 (EVEN)
5	RX02-	Negative Transmission data of Pixel 2 (ODD)	20	RXEC-	Negative Transmission Clock (EVEN)
6	RX02+	Positive Transmission data of Pixel 2 (ODD)	21	RXEC+	Positive Transmission Clock (EVEN)
7	GND	Power Ground	22	RXE3-	Negative Transmission data of Pixel 3 (EVEN)
8	RXOC-	Negative Transmission Clock (ODD)	23	RXE3+	Positive Transmission data of Pixel 3 (EVEN)
9	RXOC+	Positive Transmission Clock (ODD)	24	GND	Power Ground
10	RX03-	Negative Transmission data of Pixel 3 (ODD)	25	CTL	CTL_DVR for LCD manufacturer
11	RX03+	Positive Transmission data of Pixel 3 (ODD)	26	CE	CE_DVR for LCD manufacturer
12	RXE0-	Negative Transmission data of Pixel 0 (EVEN)	27	NC	Not connection
13	RXE0+	Positive Transmission data of Pixel 0 (EVEN)	28	VDD	Power Supply : +12V
14	GND	Power Ground	29	VDD	
15	RXE1-	Negative Transmission data of Pixel 1 (EVEN)	30	VDD	

Pin No	Symbol	Description	Pin No	Symbol	Description
31	NC	Not connection	36	GND	Power Ground
32	GND	Power Ground	37	VLED	LED Power Supply : +12V
33	LED_EN	LED Enable : 3.3V	38	VLED	
34	PWM	Dimming : 3.3V	39	VLED	
35	GND	Power Ground	40	VLED	

- Notes : 1. NC(Not Connected) : This pins are only used for BOE internal operations.  
 2. Input Level of LVDS signal is based on the EIA-644 Standard.

**Front view of LCM**

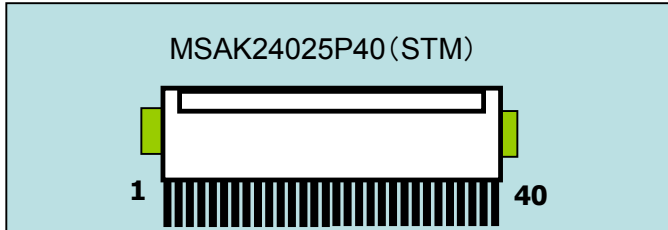

**BIST Pattern**



## 4.2 LVDS Interface

- LVDS Receiver : Timing Controller (LVDS Rx merged) / LVDS Data : Pixel Data

< Table 5. Open Cell Input Connector Pin Configuration >

Channel No.	Data No.	8-bit LVDS Type	
		NS	JEIDA
0	Bit-0	R0	R2
	Bit-1	R1	R3
	Bit-2	R2	R4
	Bit-3	R3	R5
	Bit-4	R4	R6
	Bit-5	R5	R7
	Bit-6	G0	G2
1	Bit-0	G1	G3
	Bit-1	G2	G4
	Bit-2	G3	G5
	Bit-3	G4	G6
	Bit-4	G5	G7
	Bit-5	B0	B2
	Bit-6	B1	B3
2	Bit-0	B2	B4
	Bit-1	B3	B5
	Bit-2	B4	B6
	Bit-3	B5	B7
	Bit-4	HS	HS
	Bit-5	VS	VS
	Bit-6	DE	DE
3	Bit-0	R6	R0
	Bit-1	R7	R1
	Bit-2	G6	G0
	Bit-3	G7	G1
	Bit-4	B6	B0
	Bit-5	B7	B1
	Bit-6	-	

### 4.3 LVDS Rx Interface Timing Parameter

The specification of the LVDS Rx interface timing parameter is shown in Table 6.

<Table 6. LVDS Rx Interface Timing Specification>

Item	Symbol	Min	Typ	Max	Unit	Remark
CLKIN Period	tRCIP	10.31	13.47(10.78)	15.87	nsec	
Input Data 0	tRIP1	-0.42	0.0	+0.42	nsec	
Input Data 1	tRIP0	tRCIP/7-0.42	tRCIP/7	tRCIP/7+0.42	nsec	
Input Data 2	tRIP6	2 × tRCIP/7-0.42	2 × tRCIP/7	2 × tRCIP/7+0.42	nsec	
Input Data 3	tRIP5	3 × tRCIP/7-0.42	3 × tRCIP/7	3 × tRCIP/7+0.42	nsec	
Input Data 4	tRIP4	4 × tRCIP/7-0.42	4 × tRCIP/7	4 × tRCIP/7+0.42	nsec	
Input Data 5	tRIP3	5 × tRCIP/7-0.42	5 × tRCIP/7	5 × tRCIP/7+0.42	nsec	
Input Data 6	tRIP2	6 × tRCIP/7-0.42	6 × tRCIP/7	6 × tRCIP/7+0.42	nsec	

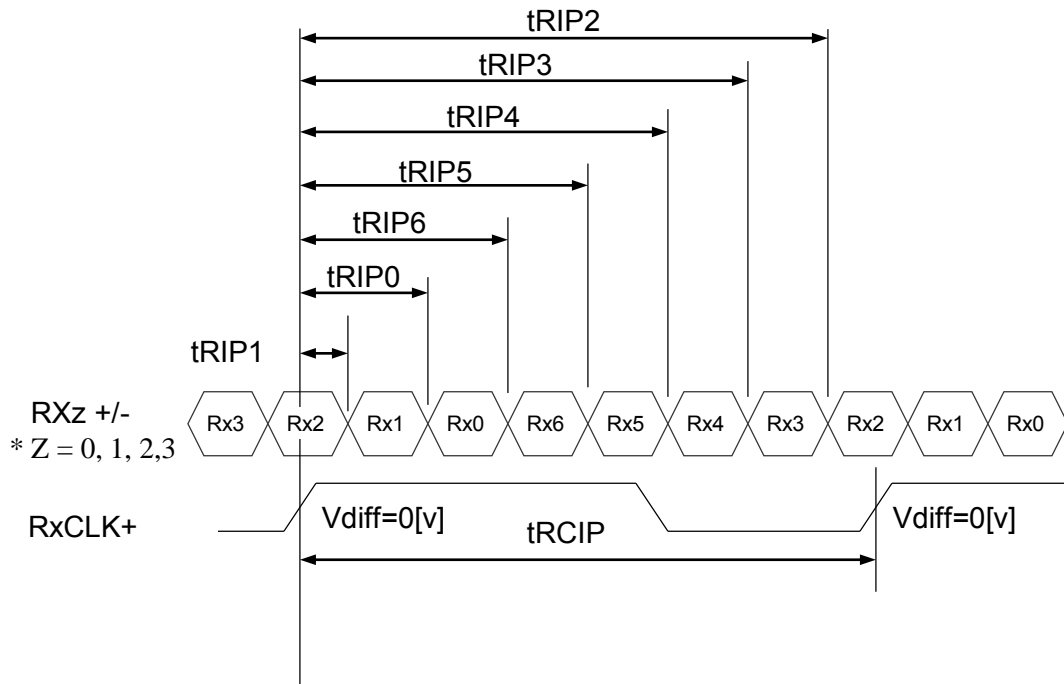

\* Vdiff = (RXz+)-(RXz-),....,(RXCLK+)-(RXCLK-)

### 4.4 LVDS Rx Interface Eye Diagram

< Table 7. LVDS Rx Interface Eye Diagram >

Symbol	Min	Typ	Max	Unit	Note
A	—	100	—	mV	
B	—	100	—	mV	
C	—	0	—	mV	
D	—	-100	—	mV	
E	—	-100	—	mV	
F	—	0	—	mV	

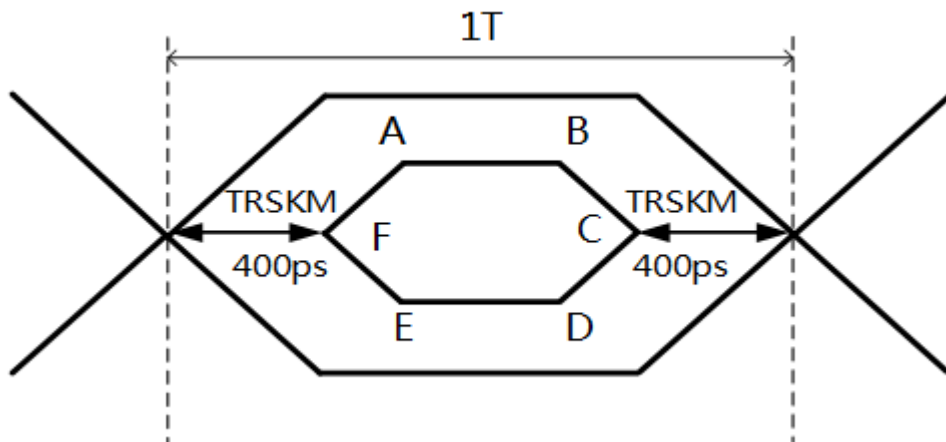

- Notes: 1. Time F to A, B to C, C to D, E to F is 150p second.
- 2. LVDS clock=85Mhz.
- 3. The time A to B= $1T-2*TRSKM-2*150ps$ .

### 4.5 LVDS Receiver Differential Input

< Table 7-1. LVDS Receiver Differential Input >

Symbol	Parameter	Min	Typ	Max	Unit	Condition
$R_{xVTH}$	Differential input high threshold voltage			+0.1V	V	$R_{xVCM} = 1.2V$
$R_{xVTL}$	Differential input low threshold voltage	-0.1V			V	
$R_{xVIN}$	Input voltage range (singled-end)	0		2.4	V	
$R_{xVCM}$	Differential input common mode voltage	$ V_{ID} /2$		$2.4 -  V_{ID} /2$	V	
$ V_{ID} $	Differential input voltage	0.1		0.6	V	

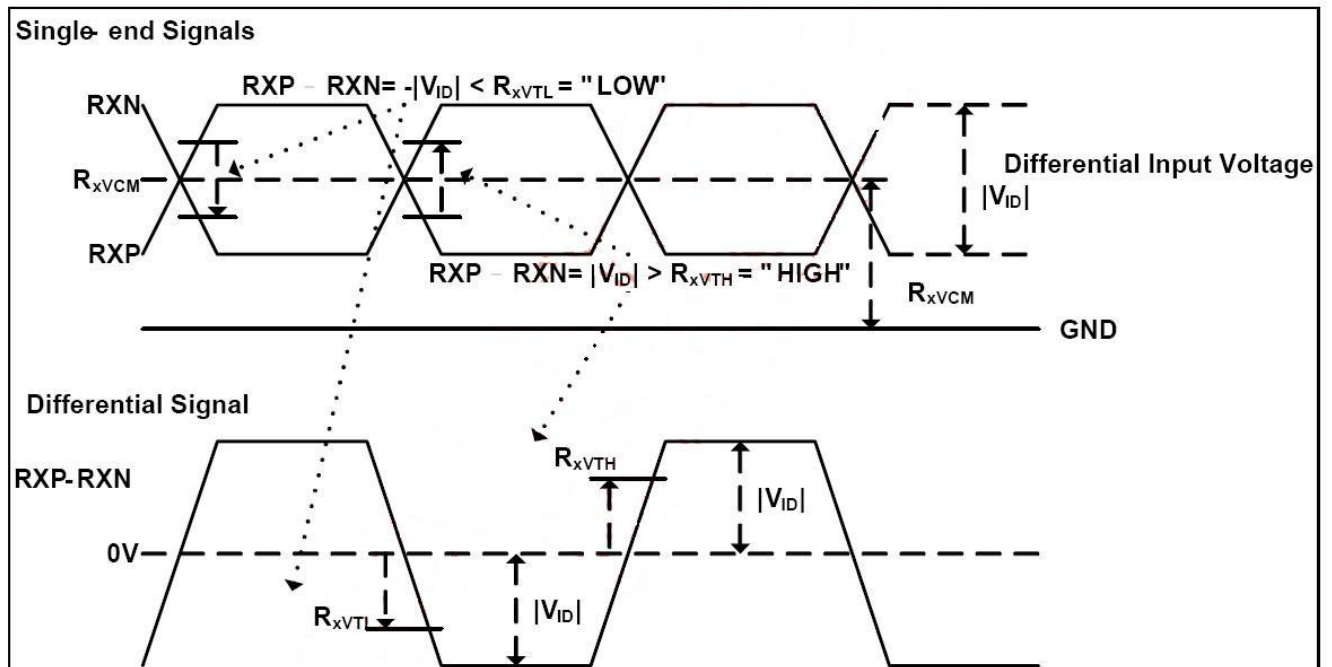

## 5.0 SIGNAL TIMING SPECIFICATION

### 5.1 Timing Parameters (DE only mode)

< Table 8. Timing Table >

Item		Symbols	Min	Typ	Max	Unit	
Clock	Frequency	1/Tc	60	74.25	78	MHz	
	High Time	Tch	-	4/7Tc	-		
	Low Time	Tcl	-	4/7Tc	-		
Frame Period		Tv	1100	1125	1149	lines	
			48.5	60	63	Hz	
Horizontal Active Display Term		Valid	t <sub>HV</sub>	-	960	-	t <sub>CLK</sub>
		Total	t <sub>HP</sub>	1060	1100	1200	t <sub>CLK</sub>
Vertical Active Display Term		Valid	t <sub>VV</sub>	-	1080	-	t <sub>HP</sub>
		Total	t <sub>VP</sub>	1100	1125	1149	t <sub>HP</sub>

Notes: This product is DE only mode. The input of Hsync & Vsync signal does not have an effect on normal operation.

< Table 9. LVDS Input SSCG >

Symbol	Parameter	Condition	Min	Typ	Max	Unit
F	LVDS Input frequency	-	60	74.25	78	MHz
T <sub>LVSK</sub>	LVDS channel to channel skew	F=100MHz V <sub>IC</sub> =1.2V V <sub>ID</sub> =±400mV	-380	-	+380	ps
F <sub>LVMOD</sub>	Modulating frequency of input clock during SSC		60	-	85	KHz
F <sub>LVDEV</sub>	Maximum deviation of input clock frequency during SSC		-3	-	+3	%
T <sub>CY-CY</sub>	Cycle to Cycle jitter		-	-	100	ps

## 5.2 Signal Timing Waveform

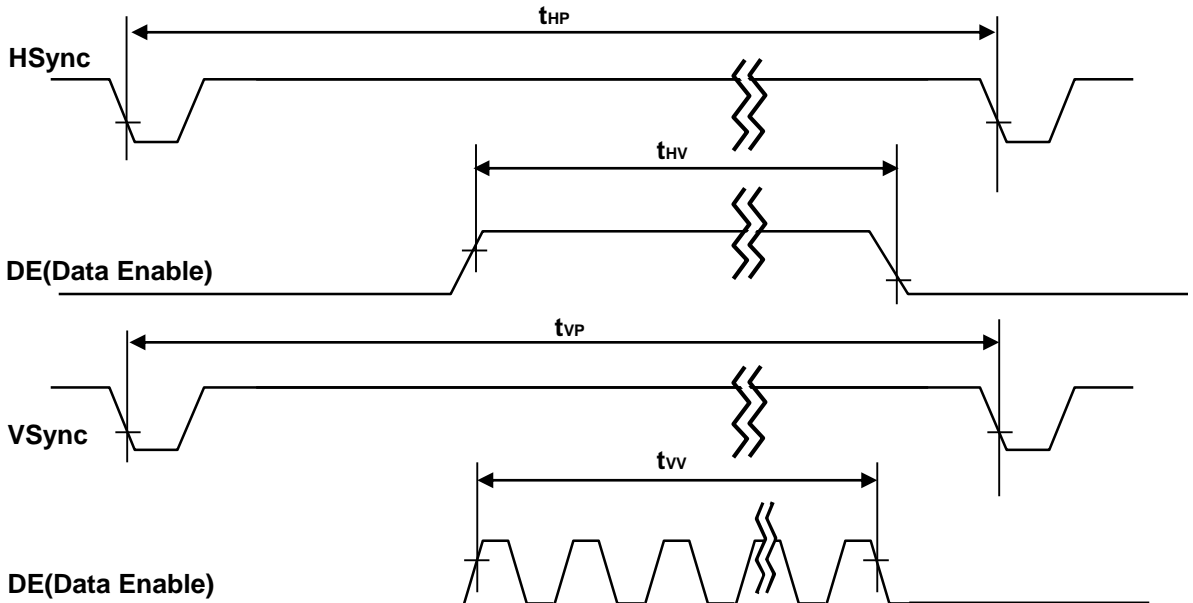
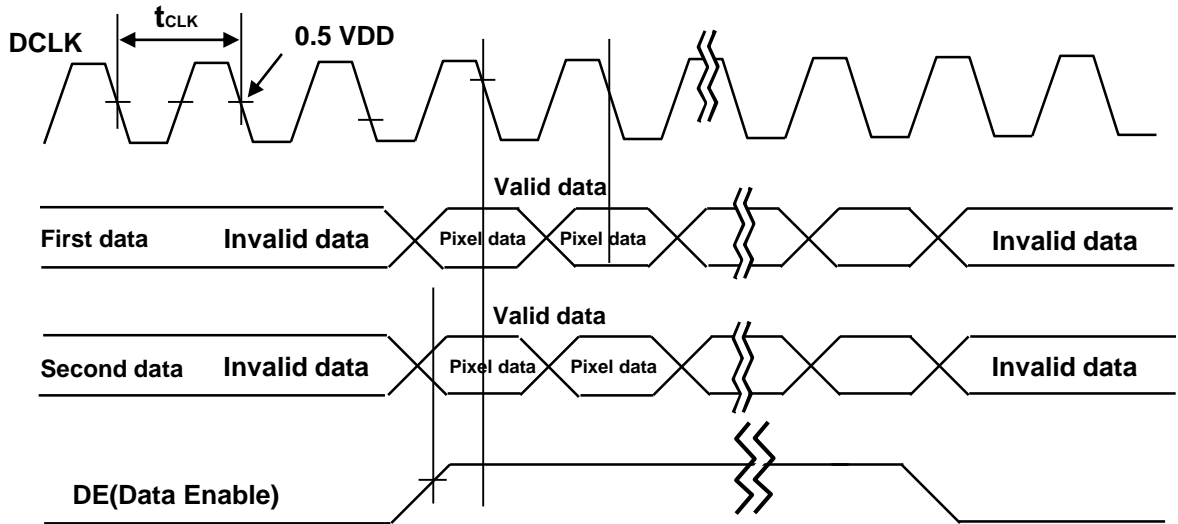



### 5.3 Input Signals, Basic Display Colors and Gray Scale of Colors

< Table 10. Input Signal and Display Color Table >

Color & Gray Scale		Input Data Signal																							
		Red Data								Green Data						Blue Data									
		R7	R6	R5	R4	R3	R2	R1	R0	G7	G6	G5	G4	G3	G2	G1	G0	B7	B6	B5	B4	B3	B2	B1	B0
Basic Colors	Black	0	0	0	0	0	0	0	0	0	0	0	0	0	0	0	0	0	0	0	0	0	0	0	0
	Blue	0	0	0	0	0	0	0	0	0	0	0	0	0	0	0	0	1	1	1	1	1	1	1	1
	Green	0	0	0	0	0	0	0	0	1	1	1	1	1	1	1	1	0	0	0	0	0	0	0	0
	Cyan	0	0	0	0	0	0	0	0	1	1	1	1	1	1	1	1	1	1	1	1	1	1	1	1
	Red	1	1	1	1	1	1	1	1	0	0	0	0	0	0	0	0	0	0	0	0	0	0	0	0
	Magenta	1	1	1	1	1	1	1	1	0	0	0	0	0	0	0	0	1	1	1	1	1	1	1	1
	Yellow	1	1	1	1	1	1	1	1	1	1	1	1	1	1	1	1	0	0	0	0	0	0	0	0
	White	1	1	1	1	1	1	1	1	1	1	1	1	1	1	1	1	1	1	1	1	1	1	1	1
Gray Scale of Red	Black	0	0	0	0	0	0	0	0	0	0	0	0	0	0	0	0	0	0	0	0	0	0	0	0
	△	0	0	0	0	0	0	0	1	0	0	0	0	0	0	0	0	0	0	0	0	0	0	0	0
	Darker	0	0	0	0	0	0	1	0	0	0	0	0	0	0	0	0	0	0	0	0	0	0	0	0
	△	↑								↑						↑									
	▽	↓								↓						↓									
	Brighter	1	1	1	1	1	1	0	1	0	0	0	0	0	0	0	0	0	0	0	0	0	0	0	0
	▽	1	1	1	1	1	1	1	0	0	0	0	0	0	0	0	0	0	0	0	0	0	0	0	0
	Red	1	1	1	1	1	1	1	1	0	0	0	0	0	0	0	0	0	0	0	0	0	0	0	0
Gray Scale of Green	Black	0	0	0	0	0	0	0	0	0	0	0	0	0	0	0	0	0	0	0	0	0	0	0	0
	△	0	0	0	0	0	0	0	0	0	0	0	0	0	0	0	1	0	0	0	0	0	0	0	0
	Darker	0	0	0	0	0	0	0	0	0	0	0	0	0	0	1	0	0	0	0	0	0	0	0	0
	△	↑								↑						↑									
	▽	↓								↓						↓									
	Brighter	0	0	0	0	0	0	0	0	1	1	1	1	1	1	0	1	0	0	0	0	0	0	0	0
	▽	0	0	0	0	0	0	0	0	1	1	1	1	1	1	0	0	0	0	0	0	0	0	0	0
	Green	0	0	0	0	0	0	0	0	1	1	1	1	1	1	1	1	0	0	0	0	0	0	0	0
Gray Scale of Blue	Black	0	0	0	0	0	0	0	0	0	0	0	0	0	0	0	0	0	0	0	0	0	0	0	0
	△	0	0	0	0	0	0	0	0	0	0	0	0	0	0	0	0	0	0	0	0	0	0	0	1
	Darker	0	0	0	0	0	0	0	0	0	0	0	0	0	0	0	0	0	0	0	0	0	0	1	0
	△	↑								↑						↑									
	▽	↓								↓						↓									
	Brighter	0	0	0	0	0	0	0	0	0	0	0	0	0	0	0	0	1	1	1	1	1	1	0	1
	▽	0	0	0	0	0	0	0	0	0	0	0	0	0	0	0	0	1	1	1	1	1	1	1	0
	Blue	0	0	0	0	0	0	0	0	0	0	0	0	0	0	0	0	1	1	1	1	1	1	1	1
Gray Scale of White	Black	0	0	0	0	0	0	0	0	0	0	0	0	0	0	0	0	0	0	0	0	0	0	0	0
	△	0	0	0	0	0	0	0	1	0	0	0	0	0	0	0	1	0	0	0	0	0	0	0	1
	Darker	0	0	0	0	0	0	1	0	0	0	0	0	0	0	1	0	0	0	0	0	0	0	1	0
	△	↑								↑						↑									
	▽	↓								↓						↓									
	Brighter	1	1	1	1	1	1	0	1	1	1	1	1	1	1	0	1	1	1	1	1	1	1	0	1
	▽	1	1	1	1	1	1	1	0	1	1	1	1	1	1	0	1	1	1	1	1	1	1	1	0
	White	1	1	1	1	1	1	1	1	1	1	1	1	1	1	1	1	1	1	1	1	1	1	1	1

### 5.4 Power Sequence

To prevent a latch-up or DC operation of the Open Cell, the power on/off sequence shall be as shown in below

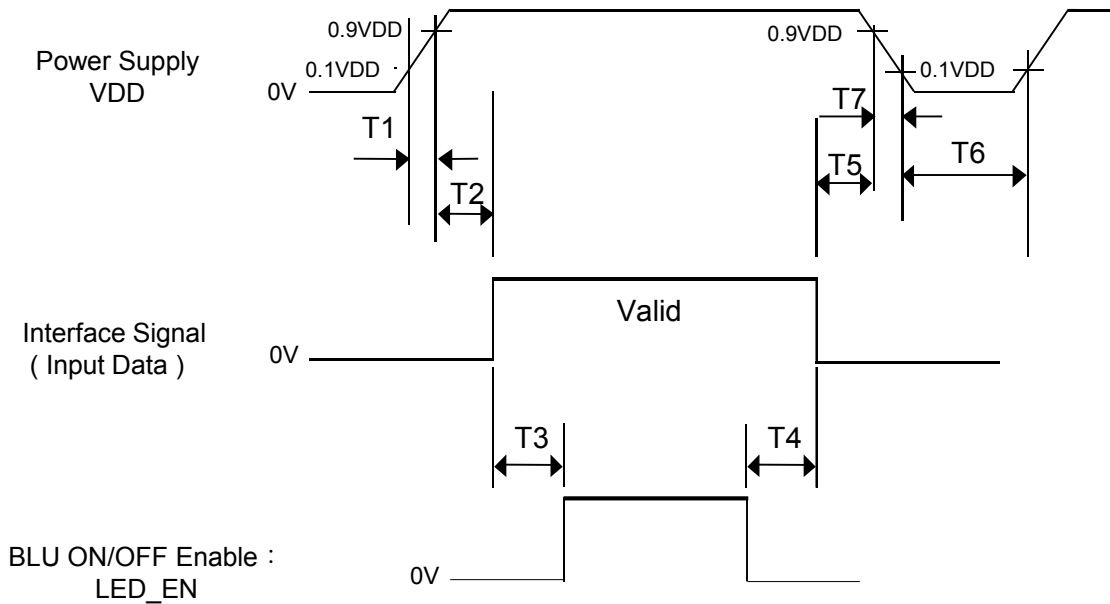

< Table 11. Sequence Table >

Parameter	Values			Units
	Min	Typ	Max	
T1	0.5	-	20	ms
T2	10	-	100	ms
T3	200	-	-	ms
T4	200	-	-	ms
T5	0	-	-	ms
T6	1	-	-	s

- Notes:
1. Back Light must be turn on after power for logic and interface signal are valid.
  2. Even though T1 is out of SPEC, it is still ok if the inrush current of VDD is below the limit.
  3. When  $VDD < 0.9VDD(Typ.)$ , Power off.
  4. T7 decreases smoothly, if there were rebounding voltage, it must smaller than 5 volts.

## 6.0 OPTICAL SPECIFICATIONS

The test of optical specifications shall be measured in a dark room (ambient luminance  $\leq 1$  lux and temperature  $= 25 \pm 2^\circ\text{C}$ ) with the equipment of Luminance meter system (Goniometer system and PR730) and test unit shall be located at an approximate distance 180cm from the LCD surface at a viewing angle of  $\theta$  and  $\Phi$  equal to  $0^\circ$ . We refer to  $\theta_{\Phi=0}$  ( $=\theta_3$ ) as the 3 o'clock direction (the "right"),  $\theta_{\Phi=90}$  ( $=\theta_{12}$ ) as the 12 o'clock direction ("upward"),  $\theta_{\Phi=180}$  ( $=\theta_9$ ) as the 9 o'clock direction ("left") and  $\theta_{\Phi=270}$  ( $=\theta_6$ ) as the 6 o'clock direction ("bottom"). While scanning  $\theta$  and/or  $\Phi$ , the center of the measuring spot on the Display surface shall stay fixed. The measurement shall be executed after 30 minutes warm-up period. VDD shall be 12.0V at  $25^\circ\text{C}$ . Optimum viewing angle direction is 6 'clock.

< Table 12. Optical Table >

[VDD = 12.0V, Frame rate = 60Hz, Ta =  $25 \pm 2^\circ\text{C}$ ]

Parameter		Symbol	Condition	Min	Typ	Max	Unit	Remark
Viewing Angle	Horizontal	$\Theta_3$	CR > 10		89		Deg.	Note 1
		$\Theta_9$			89		Deg.	
	Vertical	$\Theta_{12}$			89		Deg.	
		$\Theta_6$			89		Deg.	
Brightness		Lv		250	300		nit	
Contrast ratio		CR		800:1	1200:1	-		Note 2
Reproduction of color	White	$W_x$	$\Theta = 0^\circ$ (Center) Normal Viewing Angle	TYP. - 0.03	0.313	TYP. + 0.03		Note 3
		$W_y$			0.329			
	Red	$R_x$			0.643			
		$R_y$			0.328			
	Green	$G_x$			0.303			
		$G_y$			0.619			
	Blue	$B_x$			0.154			
		$B_y$			0.067			
Response Time	G to G	$T_g$		-	8	10	ms	Note 4
Gamma Scale				2.0	2.2	2.4		
Cell Transmittance				5.9	5.15%		%	Note 5

Note :

1. Viewing angle is the angle at which the contrast ratio is greater than 10. The viewing are determined for the horizontal or 3, 9 o'clock direction and the vertical or 6, 12 o'clock direction with respect to the optical axis which is normal to the LCD surface.
2. Contrast measurements shall be made at viewing angle of  $\theta = 0^\circ$  and at the center of the LCD surface. Luminance shall be measured with all pixels in the view field set first to white, then to the dark (black) state. (See Figure 1 shown in Appendix) Luminance Contrast Ratio (CR) is defined mathematically.

$$CR = \frac{\text{Luminance when displaying a white raster}}{\text{Luminance when displaying a black raster}}$$

3. The color chromaticity coordinates specified in Table 9 shall be calculated from the spectral data measured with all pixels first in red, green, blue and white. Measurements shall be made at the center of the panel. The BLU is used by BOE.
4. Response time  $T_g$  is the average time required for display transition by switching the input signal as below table and is based on Frame rate  $f_V = 60\text{Hz}$  to optimize. Each time in below table is defined as Figure 2 and shall be measured by switching the

Measured Response Time	Target																	
	0	15	31	47	63	79	95	111	127	143	159	175	191	207	223	239	255	
Start	0																	
	15																	
	31																	
	47																	
	63																	
	79																	
	95																	
	111																	
	127																	
	143																	
	159																	
	175																	
	191																	
	207																	
	223																	
	239																	
255																		

5. Definition of Transmittance (T%) :  
Module is with white(L255) signal input

$$\text{Transmittance} = \frac{\text{Luminance of LCD Module}}{\text{Luminance of BLU}} \times 100 \%$$

## 7.0 MECHANICAL CHARACTERISTICS

### 7.1 Dimensional Requirements

Figure 3(located in Appendix) shows mechanical outlines for the model HV430FHB-N10. Other parameters are shown in Table 13.

< Table 13. Dimensional Parameters >

Parameter	Specification	Unit
Dimensional outline	542.4(H) × 52.7(V) × 8.0(B)	mm
Weight	505	gram
Active area	529.416(H) × 36.39735(V)	mm
Pixel pitch	91.9125(H) × 275.7375(V)	mm
Number of pixels	1920(H) × 132(V) (1 pixel = R + G + B dots)	pixels
Back-light	Up edge side 1-LED Light bar Type	

### 7.2 Mounting

See FIGURE 5. (shown in Appendix)

### 7.3 Anti-Glare and Polarizer Hardness.

The surface of the LCD has an anti-glare coating to minimize reflection and a coating to reduce scratching.

## 8.0 RELIABILITY TEST

The Reliability test items and its conditions are shown in below.

< Table 14. Reliability Test Parameters >

No	Test Items	Conditions
1	High temperature storage test	Ta = 60 °C, 240 hrs
2	Low temperature storage test	Ta = -20 °C, 240 hrs
3	High temperature & high humidity operation test	Ta = 50 °C, 80%RH, 240hrs
4	High temperature operation test	Ta = 50 °C, 240hrs
5	Low temperature operation test	Ta = -5 °C, 240hrs
6	Thermal shock	Ta = -20 °C ↔ 60 °C (0.5 hr), 100 cycle

This test condition is based on BOE module.

## 9.0 PACKING INFORMATION

BOE provides the standard shipping container for customers, unless customer specifies their packing information. The standard packing method and Barcode information are shown in below.

### 9.1 Packing Order

Put 1 EPO bottom into the inner box.

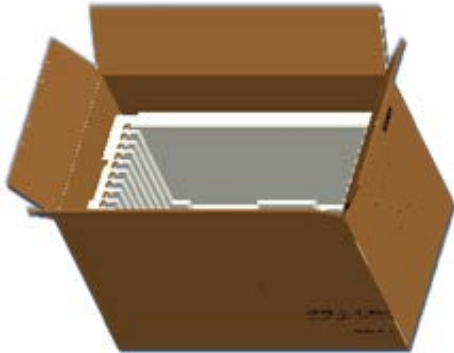

Put each module into a PE bag.  
Insert 8 Pcs MDL into each box

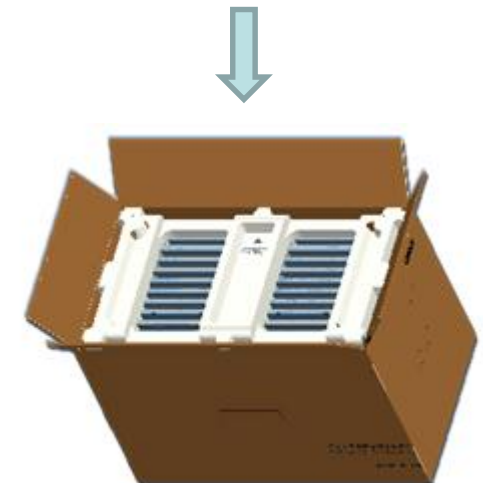
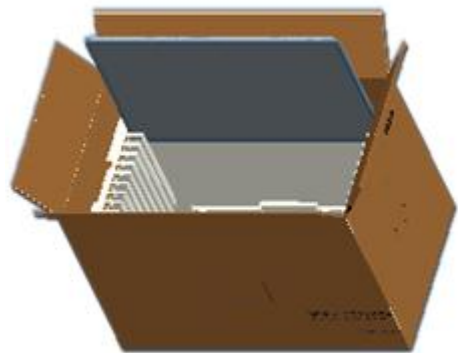

Put totally 36 boxes. Place paper corners and wrap film around the boxes. Pack with 4 packing belts.

Put 1 EPO cover in and seal the box.

### 9.2 Packing Note

- Box Dimension : 639mm(L)×310mm(W)×142mm(H)
- Package Quantity in one Box : 8pcs

## 10.0 HANDLING & CAUTIONS

- (1) Cautions when taking out the module
  - Pick the pouch only, when taking out module from a shipping package.
- (2) Cautions for handling the module
  - As the electrostatic discharges may break the LCD module, handle the LCD module with care. Peel a protection sheet off from the LCD panel surface as slowly as possible.
  - As the LCD panel and back - light element are made from fragile glass material, impulse and pressure to the LCD module should be avoided.
  - As the surface of the polarizer is very soft and easily scratched, use a soft dry cloth without chemicals for cleaning.
  - Do not pull the interface connector in or out while the LCD module is operating.
  - Put the module display side down on a flat horizontal plane.
  - Handle connectors and cables with care.
- (3) Cautions for the operation
  - When the module is operating, do not lose CLK, ENAB signals. If any one of these signals is lost, the LCD panel would be damaged.
  - Obey the supply voltage sequence. If wrong sequence is applied, the module would be damaged.
- (4) Cautions for the atmosphere
  - Dew drop atmosphere should be avoided.
  - Do not store and/or operate the LCD module in a high temperature and/or humidity atmosphere. Storage in an electro-conductive polymer packing pouch and under relatively low temperature atmosphere is recommended.
- (5) Cautions for the module characteristics
  - Do not apply fixed pattern data signal to the LCD module at product aging.
  - Applying fixed pattern for a long time may cause image sticking.
- (6) Other cautions
  - Do not disassemble and/or re-assemble LCD module.
  - Do not re-adjust variable resistor or switch etc.
  - When returning the module for repair or etc., Please pack the module not to be broken. We recommend to use the original shipping packages.



**11.0 APPENDIX**

< Figure 1. Measurement Set Up >

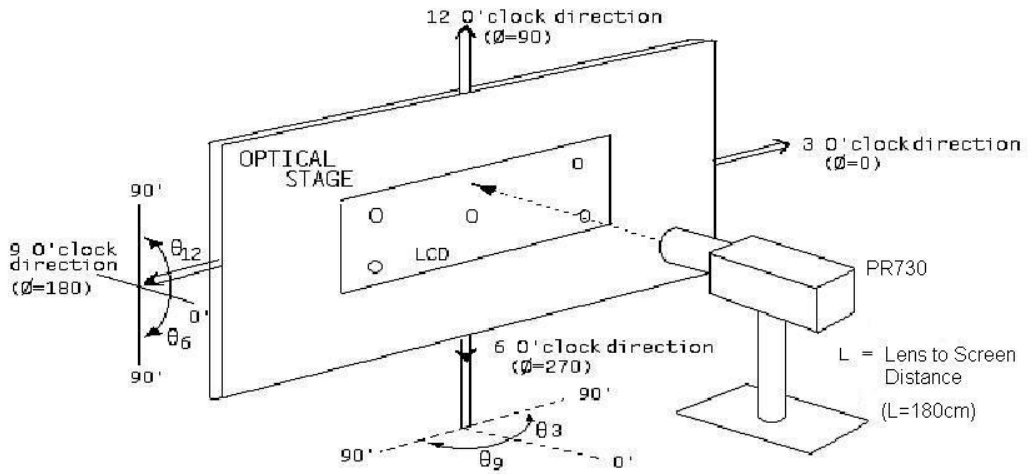

< Figure 2. Response Time Testing >

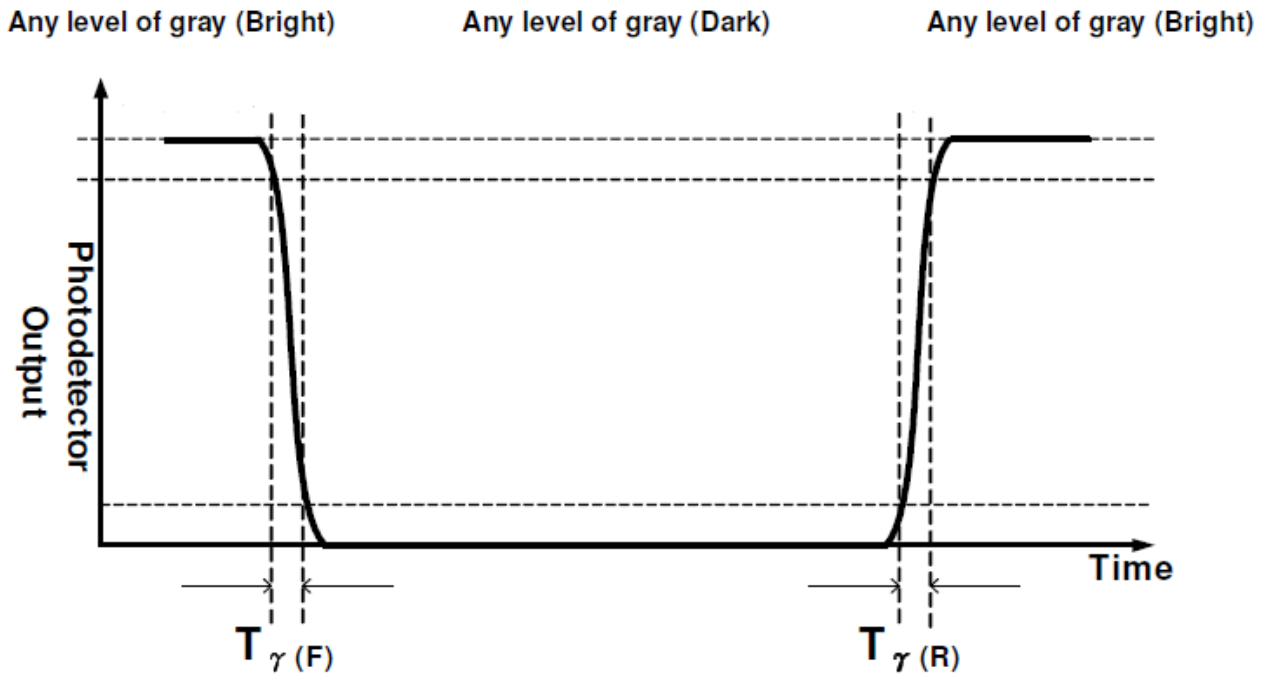

< Figure 3.TFT-LCD Module Outline Dimensions (Front View) >

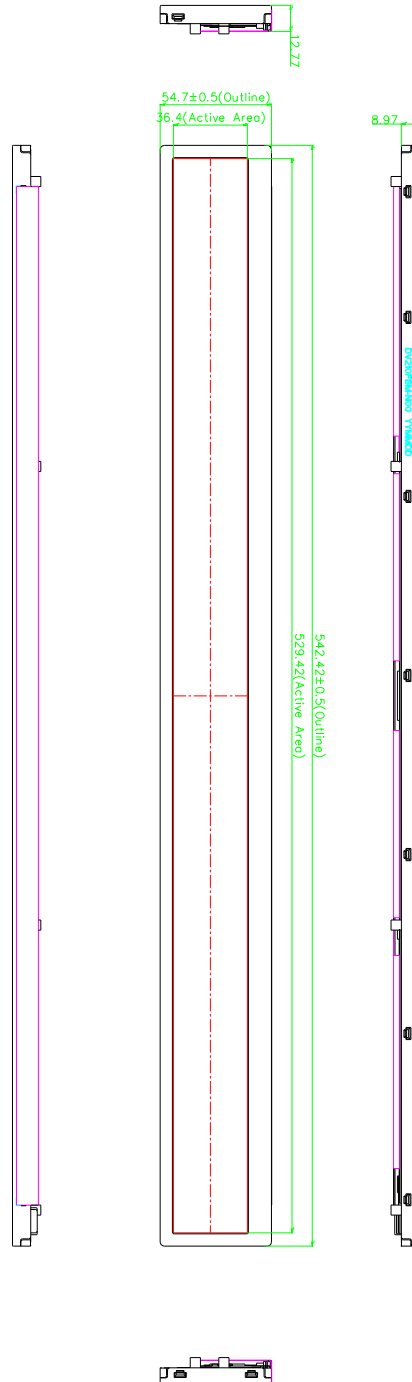

< Figure 4.TFT-LCD Module Outline Dimensions (Rear View) >

