



## **4.6 inch Bar LCD Panel Series**



**GDS046TZY37KV-GF35**

Dalian Good Display Co., Ltd.

---

## Table of Contents

1. Record of Revision.....	3
2. General Specifications.....	4
3. Input/Output Terminals.....	5
4. Absolute Maximum Rating.....	6
5. Electrical Characteristics.....	6
6. Interface Timing.....	8
7. Optical Characteristics.....	14
8. Environmental / Reliability Tests.....	18
9. Mechanical Drawing.....	19
10. Packing.....	20
11. TFT-LCD Module Inspection Criteria.....	21
12. Precautions for Use of LCD modules.....	26

## 1. Record of Revision

<b>Rev</b>	<b>Issued Date</b>	<b>Description</b>	<b>Editor</b>
1.0	2017/3/13	First Release.	
2.0	2017/8/17	Update luminance.	
3.0	2018/7/3	Update interface description	

## 2. General Specifications

	Feature	Spec
Characteristics	Size	4.6 inch
	Resolution	800(horizontal)*320(Vertical)
	Interface	RGB-24bit
	Connect type	ZIF Connector:(FH12-50S-0.5SH)
	Display Colors	16.7M
	Technology type	a-Si
	Pixel pitch (mm)	0.135*0.135
	Pixel Configuration	R.G.B.-Stripe
	Display Mode	Normally White
	Driver IC	ILI5960+ILI6122
	Touch IC	HY4613
	Viewing Direction	12 O'clock
Mechanical	LCM (W x H x D) (mm)	120.70*56.16*4.87
	Active Area(mm)	108.00*43.20
	With /Without TSP	With CTP
	Weight (g)	TBD
	LED Numbers	12 LEDs

Note 1: Requirements on Environmental Protection: RoHs

Note 2: LCM weight tolerance: +/- 5%

### 3. Input/Output Terminals

#### LCD PIN-MAP

No.	Symbol	Description
1	VLED-	Backlight LED Cathode
2	VLED+	Backlight LED Anode.
3	GND	System Ground
4	VDD	Power supply for logic operation
5~12	R0~R7	Data bus
13~20	G0~G7	Data bus
21~28	B0~B7	Data bus
29	GND	System Ground
30	DCLK	Pixel clock signal
31	DISP	Display on/off control
32	HSYNC	Horizontal sync input in digital parallel RGB
33	VSYNC	Vertical sync input in digital parallel RGB
34	DEN	Data Enable
35	NC	No connect
36	GND	System Ground
37	XR(NC)	No connect
38	YD(NC)	No connect
39	XL(NC)	No connect
40	YU(NC)	No connect

#### CTP PIN-MAP

Pin	Signal	Description
1	VSS	Ground
2	VDD	Power supply
3	SCL	I2C clock input
4	VSS	Ground
5	SDA	I2C data input and output
6	VSS	Ground
7	/RST	Reset Pin for CTP
8	NC	No connect
9	/INT	Interrupt request to the host
10	VSS	Ground

## 4. Absolute Maximum Rating

Item	Symbol	MIN	Typ	MAX	Unit	Remark
Supply Voltage	VDD	-0.3	-	5	V	-
Operating Temperature	TOPR	-20	-	70	°C	-
Storage Temperature	TSTG	-30	-	80	°C	-

## 5. Electrical Characteristics

### 5.1 Driving TFT LCD Panel

Item	Symbol	MIN	TYP	MAX	Unit	Remark
Supply Voltage	VDD	3.0	3.3	3.6	V	
Input Signal Voltage	Low Level	V <sub>IL</sub>	GND	-	0.3x VDD	V
	High Level	V <sub>IH</sub>	0.7x VDD	-	VDD	V
Output Signal Voltage	Low Level	V <sub>IL</sub>	0	-	VSS+0.4	V
	High Level	V <sub>IH</sub>	VDD-0.4	-	-	V
(Panel+LSI) Power Consumption	Black Mode (60Hz)	-	74	-	-	nW
	Standby	-	50	-	-	uW

### 5.2 CTP Electrical Characteristics

FPC Design	Item	Description	Remark
<b>COF</b>	IC solution on TP Model	HY4613	
	Touch Count Max	5 point	
	Display Resolution	800*320	
	Interface Type	I2C	
	I2C Slave Address	OX70	
	Origin of Coordinate	Top left corner	

Parameter	Symbol	Min	Typ	Max	Unit
<b>Interface Signal Voltage</b>	<b>VDDI</b>	-	1.8	-	V
<b>Power Voltage</b>	<b>VDD</b>	-	3.3	-	V

### 5.3 LED Driving Conditions

Item	Symbol	MIN	TYP	MAX	Unit	Remark
Forward Current	$I_F$	-	40	50	mA	
Forward Voltage	$V_F$	18.2	19.2	20.2	V	
Backlight Power consumption	$W_{BL}$	-	0.768	-	W	
LED Lifetime		-	25000	-	Hrs	

Note 1: Each LED:  $I_F = 20\text{ mA}$ ,  $V_F = 3.2 \pm 0.2\text{ V}$ .

Note 2: Optical performance should be evaluated at  $T_a = 25^\circ\text{C}$  only.

Note 3: If LED is driven by high current, high ambient temperature & humidity condition. The life Time of LED will be reduced. Operating life means brightness goes down to 50% initial brightness. Typical operating life time is estimated data.

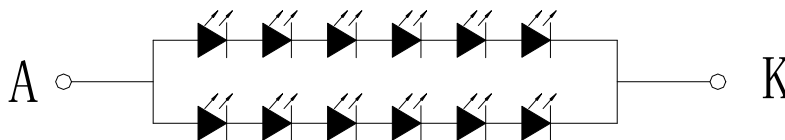
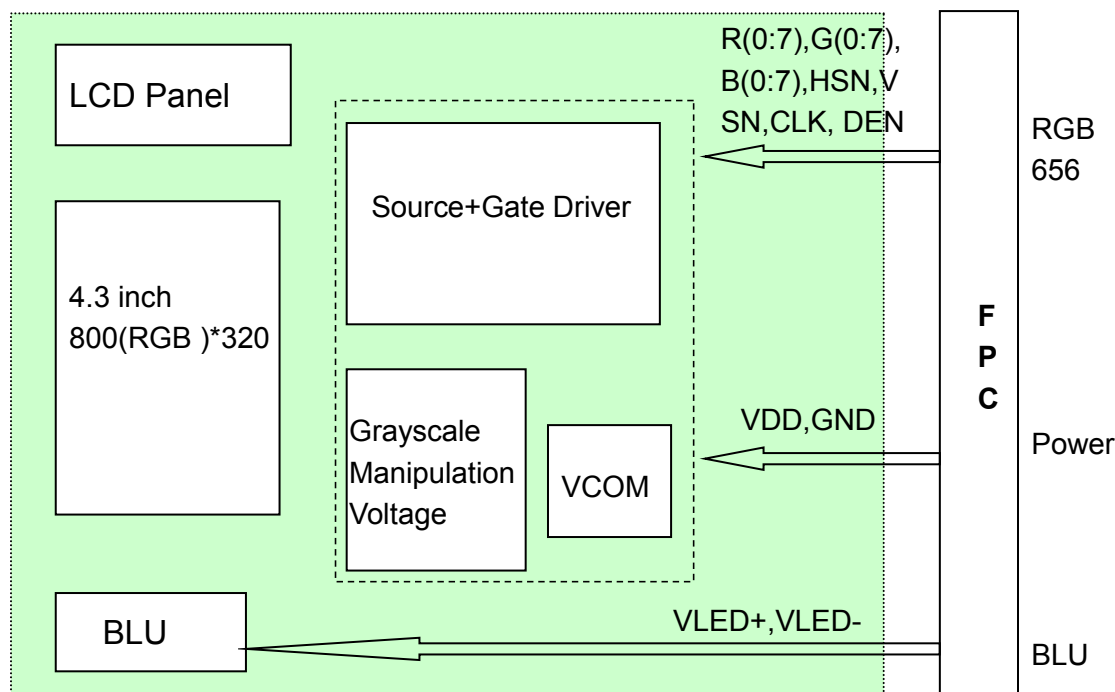

Figure: LED connection of backlight(Constant Current)

### 5.4 Block Diagram





## 6. Interface Timing

### 6.1 Power Sequence

To prevent a latch-up or DC operation of the LCD module, the power on/off sequence should be as the diagram below.

#### a. Power on sequence:

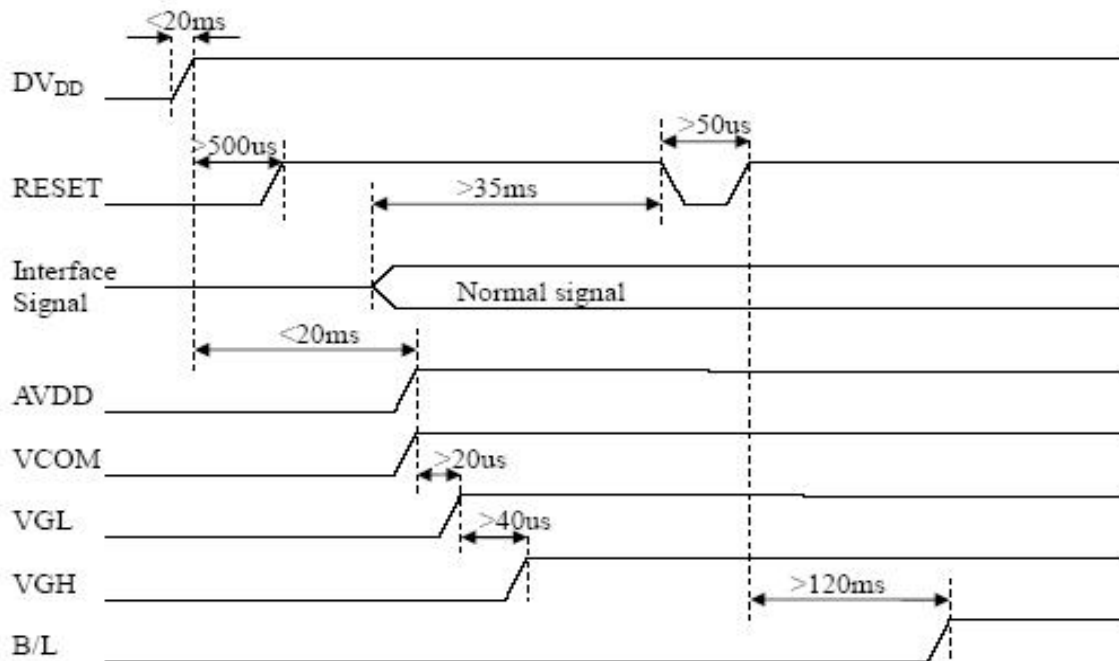

#### b. Power off sequence:

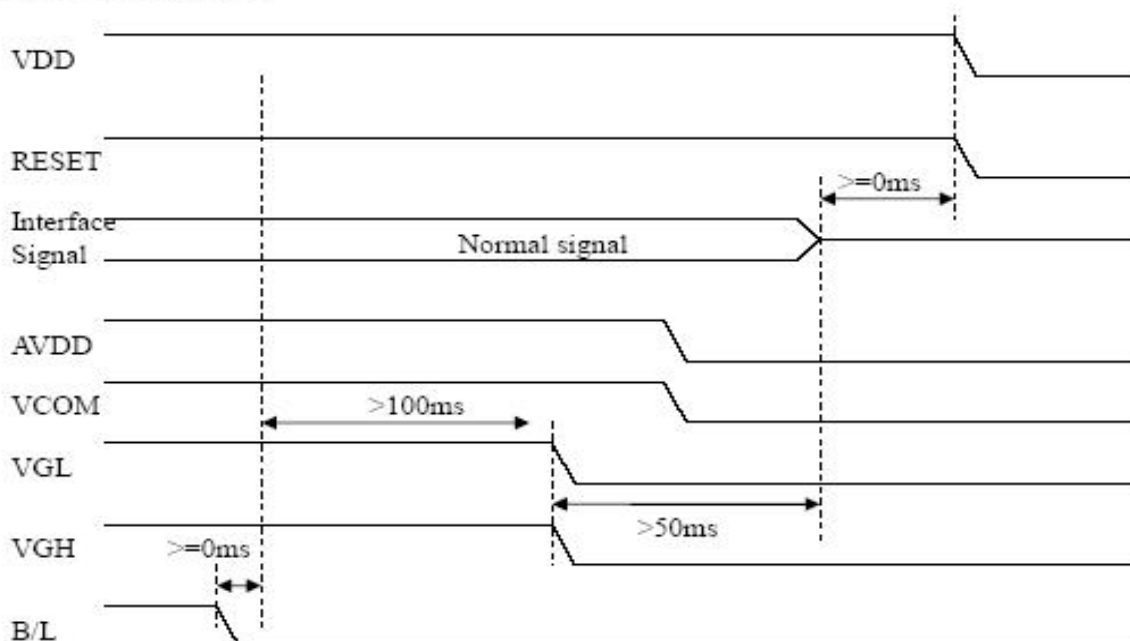



## 6.2 AC Timing characteristics

Item	Symbol	Values			Unit	Remark
		Min.	Typ.	Max.		
HS setup time	$T_{hst}$	8	-	-	ns	
HS hold time	$T_{hhd}$	8	-	-	ns	
VS setup time	$T_{vst}$	8	-	-	ns	
VS hold time	$T_{vhd}$	8	-	-	ns	
Data setup time	$T_{dsu}$	8	-	-	ns	
Data hole time	$T_{dhd}$	8	-	-	ns	
DE setup time	$T_{esu}$	8	-	-	ns	
DE hole time	$T_{ehd}$	8	-	-	ns	
DV <sub>DD</sub> Power On Slew rate	$T_{POR}$	-	-	20	ms	From 0 to 90% DV <sub>DD</sub>
RESET pulse width	$T_{Rst}$	1	-	-	ms	
DCLK cycle time	$T_{coh}$	20	-	-	ns	
DCLK pulse duty	$T_{cwh}$	40	50	60	%	

### SYNC Mode:

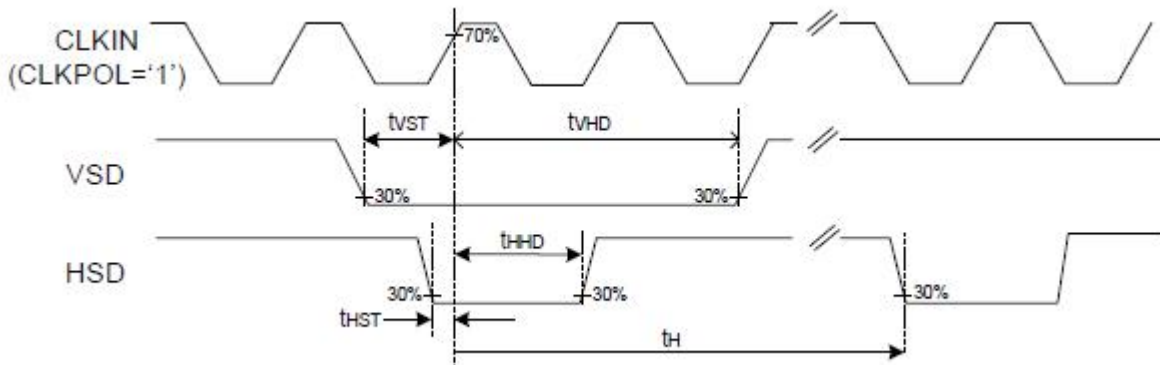

### Display Timing characteristics:

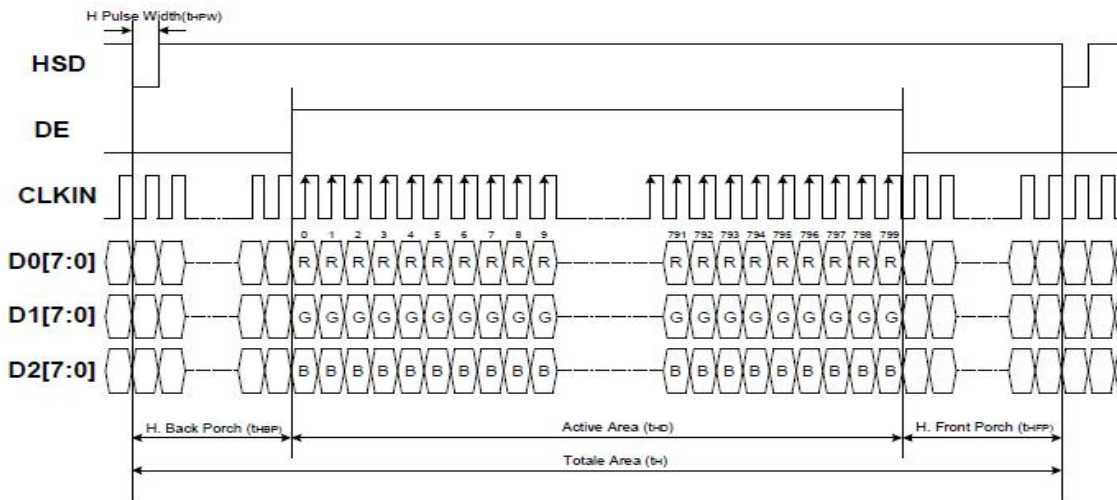

Horizontal Input Timing						
Parameter	Symbol	Value			Unit	
		Min.	Typ.	Max.		
Horizontal display area	t <sub>HD</sub>	--	800	--	CLKIN	
CLKIN frequency	f <sub>CLK</sub>	--	33.3	50	MHz	
1 Horizontal line period	t <sub>H</sub>	862	1056	1200	CLKIN	
HSD pulse width	t <sub>HPW</sub>	Min.	--	1	CLKIN	
		Typ.	--	--	CLKIN	
		Max.	--	40	CLKIN	
HSD back porch	SYNC	t <sub>HBP</sub>	46	46	46	CLKIN
HSD front porch	SYNC	t <sub>HFP</sub>	16	210	354	CLKIN

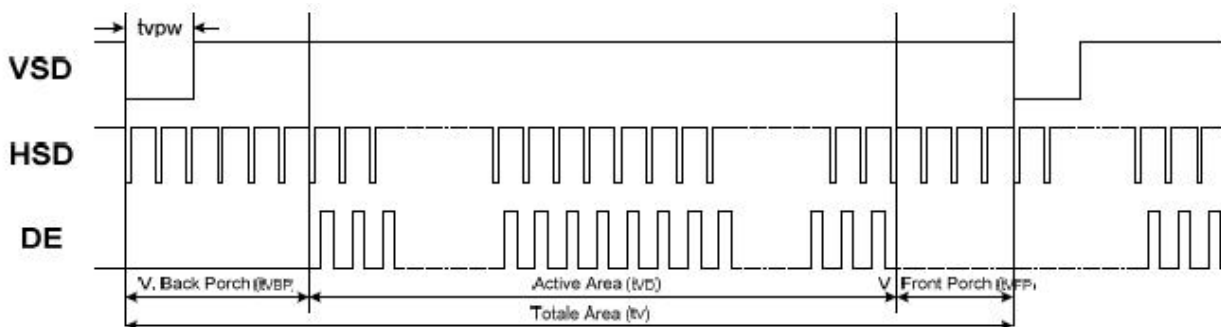

Item	Symbol	Values			Unit	Remark
		Min.	Typ.	Max.		
Vertical Display Area	tvd	-	320	-	TH	
VS period time	tv	510	525	650	TH	
VS pulse width	tpw	1	-	20	TH	
VS Blanking	tvb	23	23	23	TH	
VS Front Porch	tvfp	7	22	147	TH	

## 6.5 Data Input Format

### 6.5.1 Horizontal Input Timing

**CLKPOL= "L"**

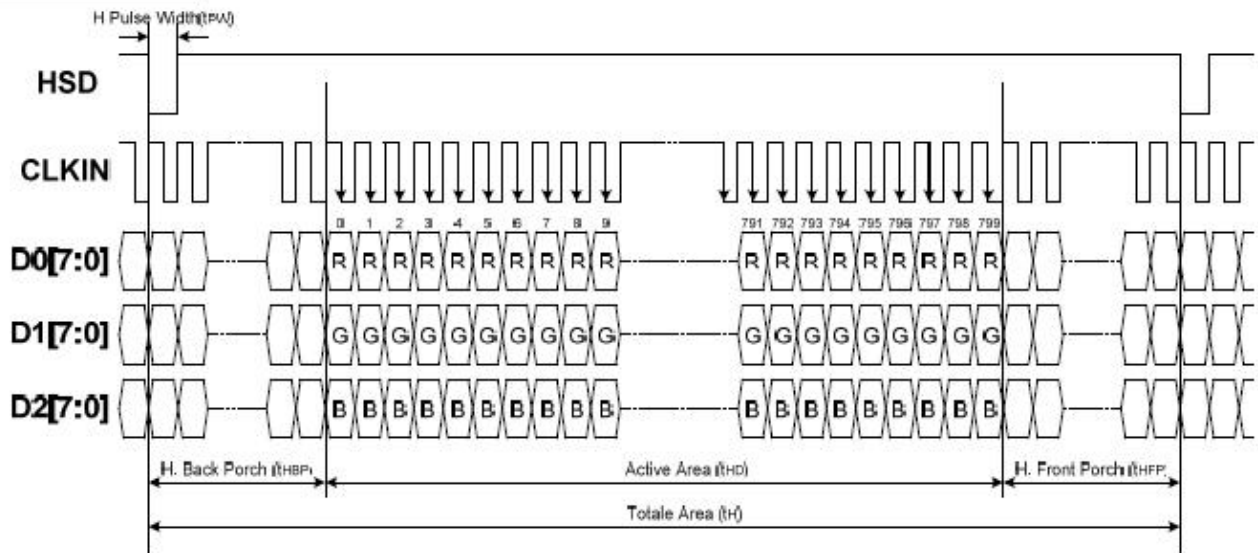

**CLKPOL= "H"**

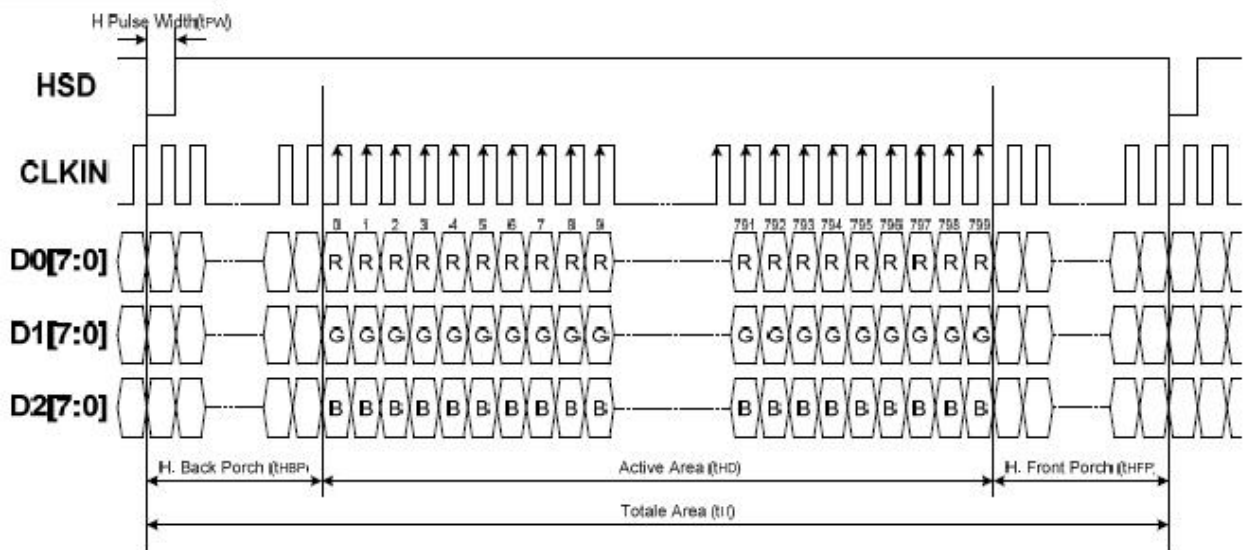

### 6.5.2 Vertical Input Timing

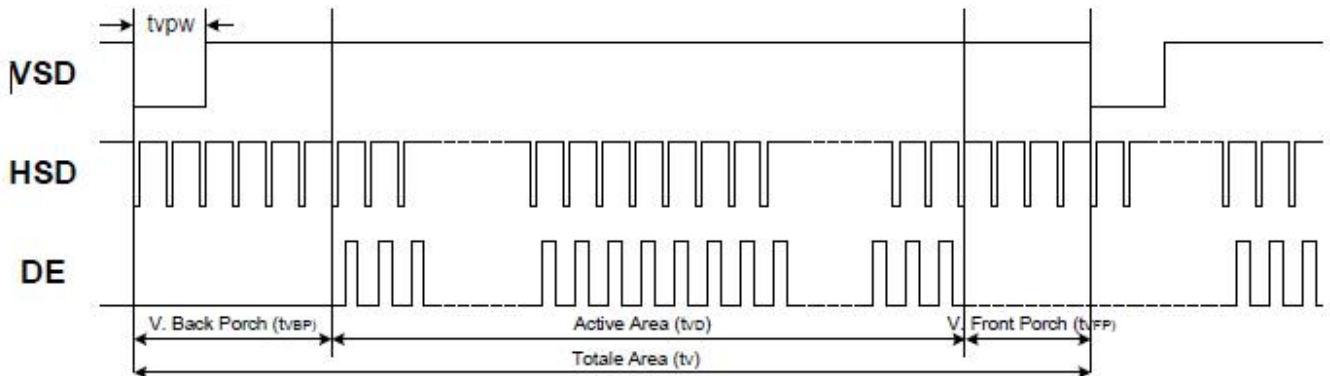

## 6.6 Capacitive touch panel Specification

### I2C

The I2C is always configured in the Slave mode. The data transfer format is shown in Figure 2-4.

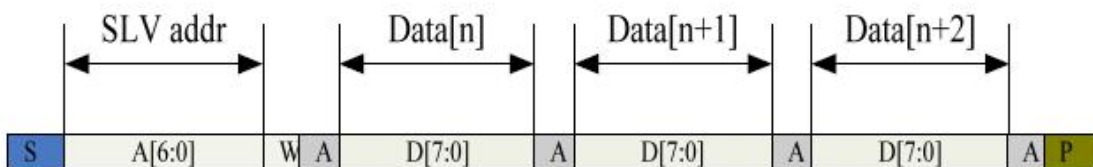
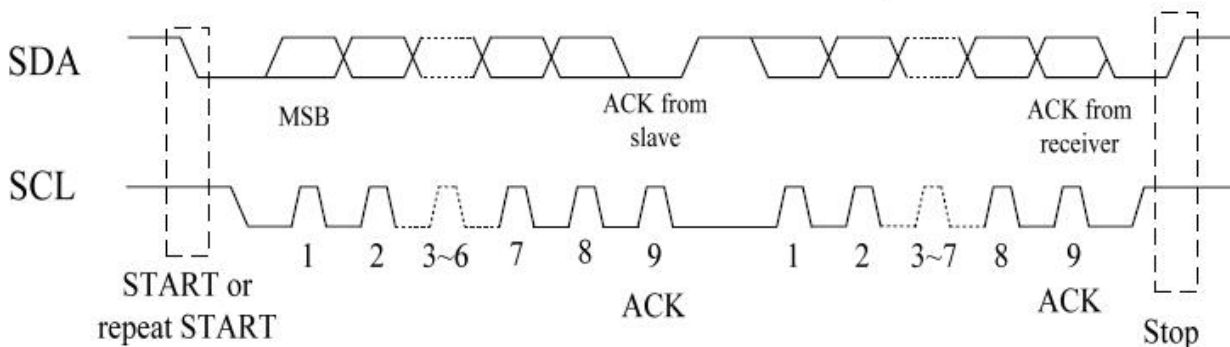

Figure 2-5 I2C master write, slave read

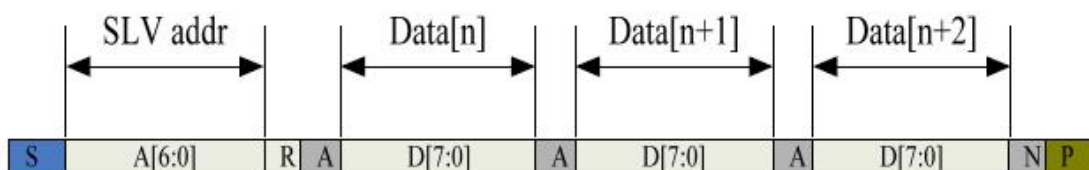

Figure 2-6 I2C master read, slave write

Table 2-1 lists the meanings of the mnemonics used in the above figures.

**Table 2-1 Mnemonics Description**

Mnemonics	Description
S	I2C Start or I2C Restart
A[6:0]	Slave address A[6:4]: 3'b011 A[3:0]: data bits are identical to those of I2CCON[7:4] register.
W	1'b0: Write
R	1'b1: Read
A(N)	ACK(NACK)
P	STOP: the indication of the end of a packet (if this bit is missing, S will indicate the end of the current packet and the beginning of the next packet)

I2C Interface Timing Characteristics is shown in Table 2-2.

**Table 2-2 I2C Timing Characteristics**

Parameter	Unit	Min	Max
SCL frequency	KHz	0	400
Bus free time between a STOP and START condition	us	4.7	\
Hold time (repeated) START condition	us	4.0	\
Data setup time	ns	250	\
Setup time for a repeated START condition	us	4.7	\
Setup Time for STOP condition	us	4.0	\

## 7. Optical Characteristics

Items		Symbol	Condition	Min.	Typ.	Max.	Unit	Remark	Note
Response time		Tr+Tf	-	-	40	60	ms	FIG.1	Note4
Contrast Ratio		CR		500	600	-	-	FIG.2	Note1
Surface luminance		LV	$\theta = 0^\circ$	-	450	-	cd/m2	FIG.2	Note2
Luminance uniformity		Yu	$\theta = 0^\circ$	80	-	-	%	FIG.2	Note3
NTSC		-	$\theta = 0^\circ$	-	50	-	%	FIG.2	Note5
Viewing angle		$\theta_T$	Center CR $\geq$ 10	40	70	-	deg	FIG.3	Note6
		$\theta_B$		60	50	-	deg	FIG.3	
		$\theta_L$		60	70	-	deg	FIG.3	
		$\theta_R$		60	70	-	deg	FIG.3	
Chromaticity	Red	R <sub>X</sub>	$\theta = 0^\circ$ $\phi = 0^\circ$ Ta=25°	0.324	0.326	0.328	-	FIG.2 CIE1931	Note5
		R <sub>Y</sub>		0.364	0.366	0.368	-		
	Green	G <sub>X</sub>		0.611	0.613	0.615	-		
		G <sub>Y</sub>		0.333	0.335	0.337	-		
	Blue	B <sub>X</sub>		0.305	0.307	0.309	-		
		B <sub>Y</sub>		0.558	0.560	0.562	-		
	White	W <sub>X</sub>		0.133	0.135	0.137	-		
		W <sub>Y</sub>		0.158	0.160	0.162	-		



**Note1. Definition of contrast ratio**

Contrast ratio(Cr) is defined mathematically by the following formula.  
For more information see FIG.2.

$$\text{Contrast ratio} = \frac{\text{Luminance measured when LCD on the "White" state}}{\text{Luminance measured when LCD on the "Black" state}}$$

For contrast ratio, Surface Luminance, Luminance uniformity and CIE, the testing data is based on TOPCON's BM-5 or BM-7 photo detector or compatible.

**Note2. Definition of surface luminance**

Surface luminance is the luminance with all pixels displaying white. For more information see FIG.2.

$L_v$  = Average Surface Luminance with all white pixels(P1,P2,P3, ...,Pn)

**Note3. Definition of luminance uniformity**

The luminance uniformity in surface luminance is determined by measuring luminance at each test position 1 through n, and then dividing the maximum luminance of n points luminance by minimum luminance of n points luminance. For more information see FIG.2.

$$Y_u = \frac{\text{Minimum surface luminance with all white pixels (P1,P2,P3, ...,Pn)}}{\text{Maximum surface luminance with all white pixels (P1,P2,P3, ...,Pn)}}$$

**Note4. Definition of response time**

The response time is defined as the LCD optical switching time interval between "White" state and "Black" state. Rise time ( $T_r$ ) is the time between photo detector output intensity changed from 90% to 10%. And fall time ( $T_f$ ) is the time between photo detector output intensity changed from 10% to 90%.

For additional information see FIG1.

**Note5. Definition of color chromaticity (CIE1931)**

CIE (x,y) chromaticity, The x,y value is determined by screen active area center position P5. For more information see FIG.2.

**Note6. Definition of viewing angle**

Viewing angle is the angle at which the contrast ratio is greater than 10. Angles are determined for the horizontal or x axis and the vertical or y axis with respect to the z axis which is normal to the LCD surface.

For more information see FIG.3.

For viewing angle and response time testing, the testing data is based on Autronic-Melchers's ConoScope or DMS series Instruments or compatible.



FIG.1. The definition of response Time

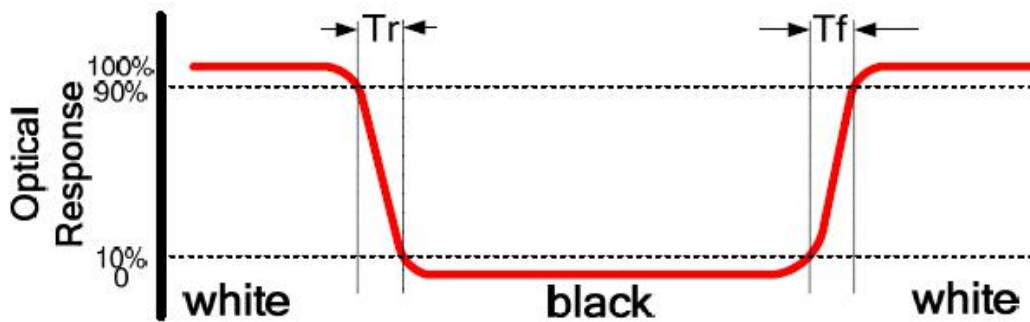

FIG.2. Measuring method for contrast ratio, surface luminance, luminance uniformity, CIE (x,y) chromaticity

Size :  $S \leq 5"$  (see Figure a)

A : 5 mm B : 5 mm

H, V : Active area

Light spot size  $\varnothing = 5\text{mm}$  (BM-5) or  $\varnothing = 7.7\text{mm}$  (BM-7) 50cm distance or compatible distance from the LCD surface to detector lens.

test spot position : see Figure a.

measurement instrument : TOPCON's luminance meter BM-5 or BM-7 or compatible (see Figure c).

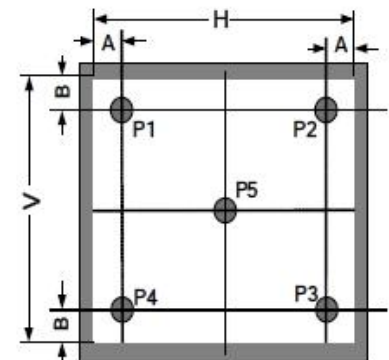

Figure a

Size :  $5" < S \leq 12.3"$  (see Figure b)

H, V : Active area

Light spot size  $\varnothing = 5\text{mm}$  (BM-5) or  $\varnothing = 7.7\text{mm}$  (BM-7) 50cm distance or compatible distance from the LCD surface to detector lens.

test spot position : see Figure b.

measurement instrument : TOPCON's luminance meter BM-5 or BM-7 or compatible (see Figure c).

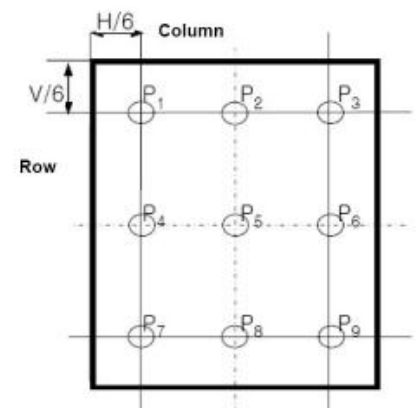

Figure b

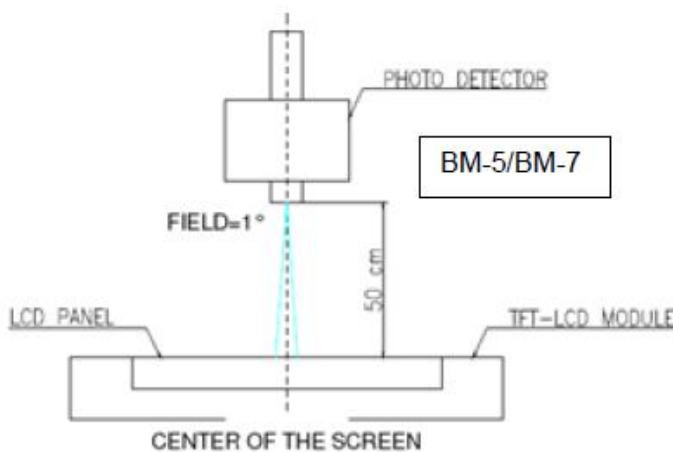
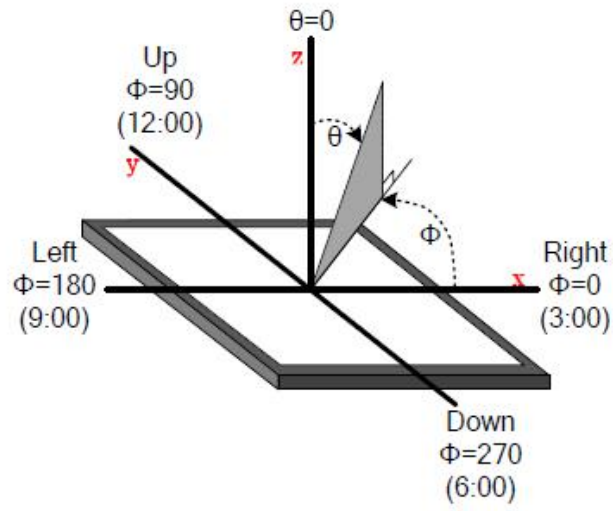

Figure c

FIG.3. The definition of viewing angle



## 8. Environmental / Reliability Tests

No	Test Item	Condition	Remarks
1	High Temperature Operation	T <sub>s</sub> = +70°C, 96hrs	Note 1 IEC60068-2-2, GB2423. 2-89
2	Low Temperature Operation	T <sub>a</sub> = -20°C, 96hrs	Note 2 IEC60068-2-1 GB2423.1-89
3	High Temperature Storage	T <sub>a</sub> = +80°C, 120hrs	IEC60068-2-2 GB2423. 2-89
4	Low Temperature Storage	T <sub>a</sub> = -30°C, 120hrs	IEC60068-2-1 GB/T2423.1-89
5	High Temperature & Humidity Storage	T <sub>a</sub> = +60°C, 90% RH max, 120 hours	IEC60068-2-3 GB/T2423.3-2006
6	Thermal Shock (Non-operation)	-20°C 30 min ~ +60°C 30 min Change time: 5min, 30 Cycle	Start with cold temperature, end with high temperature IEC60068-2-14, GB2423.22-87
7	Electro Discharge (Operation)	Static C=150pF, R=330 Ω, 5 points/panel Air:±8KV, 5 times; Contact: ±4KV, 5 times; (Environment: 15°C ~ 35°C, 30% ~ 60%, 86Kpa ~ 106Kpa)	IEC61000-4-2 GB/T17626.2-1998
8	Vibration (Non-operation)	Frequency range: 10~55Hz, Stroke: 1.mm Sweep: 10Hz~55Hz~10Hz 2 hours for each direction of X .Y. Z. (package condition)	IEC60068-2-6 GB/T2423.5-1995
9	Shock (Non-operation)	60G 6ms, ± X, ±Y , ± Z 3 times for each direction	IEC60068-2-27 GB/T2423.5-1995
10	Package Drop Test	Height: 80 cm, 1 corner, 3 edges, 6 surfaces	IEC60068-2-32 GB/T2423.8-1995

Note: 1. T<sub>s</sub> is the temperature of panel's surface.

2. T<sub>a</sub> is the ambient temperature of sample.

3. The size of sample is 5pcs.



## 10. Packing

### Packing Method

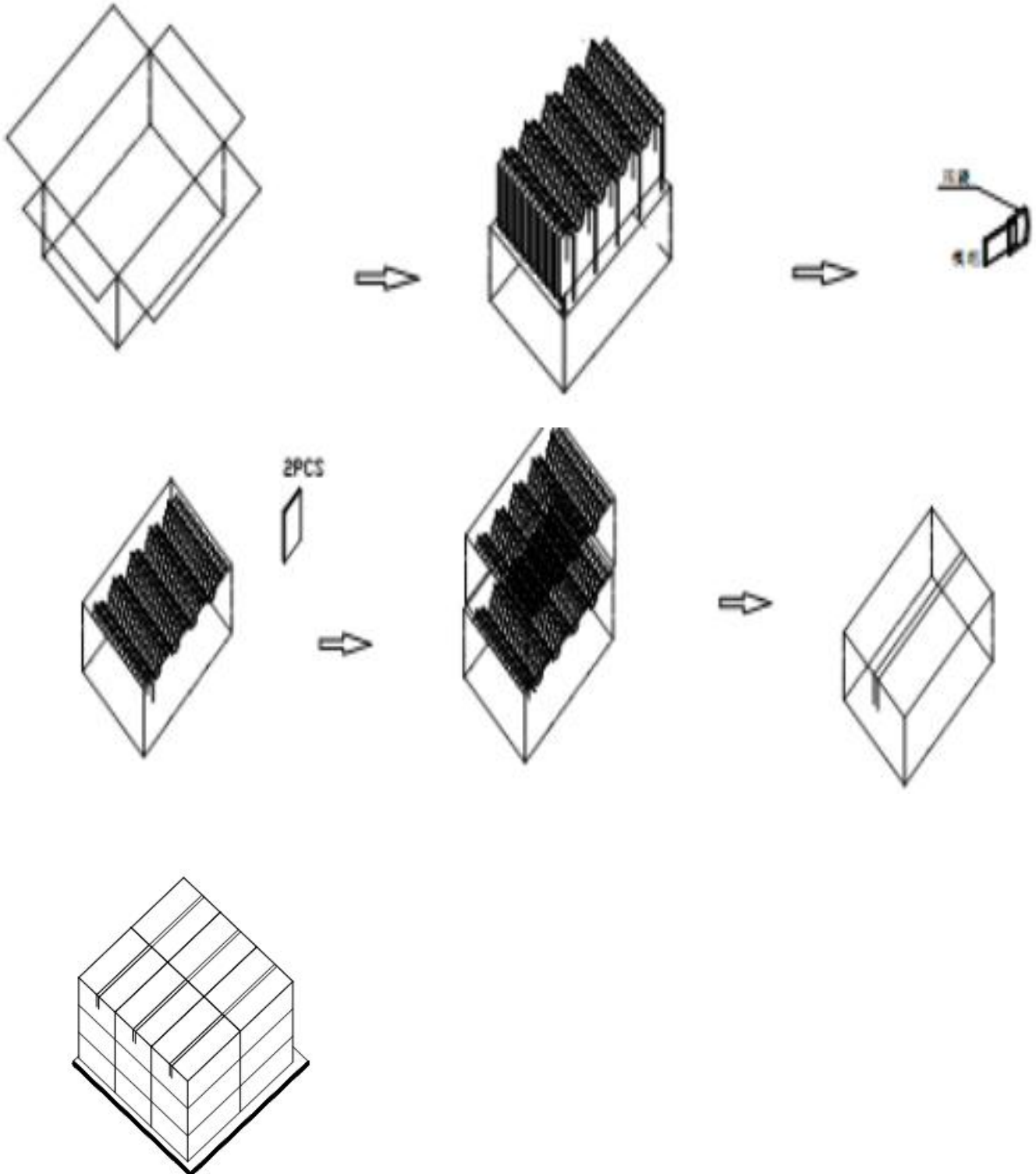

## 11. TFT-LCD Module Inspection Criteria

### 11.1 Scope

The incoming inspection standards shall be applied to TFT – LCD Modules (hereinafter Called "Modules") that supplied by Dalian Good Display Co., Ltd.

### 11.2 Incoming Inspection

The customer shall inspect the modules within twenty calendar days of the delivery date (the “inspection period”) at its own cost. The result of the inspection (acceptance or rejection) shall be recorded in writing, and a copy of this writing will be promptly sent to The seller, If the results of the inspecting from buyer does not send to the seller within twenty Calendar days of the delivery date. The modules shall be regards as acceptance. Should the customer fail to notify the seller within the inspection period, the buyers Right to reject the modules shall be lapsed and the modules shall be deemed to have Been accepted by the buyer

### 11.3 Inspection Sampling

- 3.1. Lot size: Quantity per shipment lot per model
- 3.2. Sampling type: Normal inspection, Single sampling
- 3.3. Inspection level: II
- 3.4. Sampling table: MIL-STD-105E
- 3.5. Acceptable quality level (AQL )  
Major defect: AQL=0.65 Minor defect: AQL=1.00

### 11.4 Inspection Conditions

- 4.1 Ambient conditions:
  - a. Temperature: Room temperature  $25 \pm 5^{\circ}\text{C}$
  - b. Humidity:  $(60 \pm 10) \% \text{RH}$
  - c. Illumination: Single fluorescent lamp non-directive (300 to 700 Lux)
- 4.2 Viewing distance  
The distance between the LCD and the inspector’ s eyes shall be at least  $35 \pm 5$  cm.
- 4.3 Viewing Angle  
U/D:  $45^{\circ} / 45^{\circ}$  , L/R:  $45^{\circ} / 45^{\circ}$

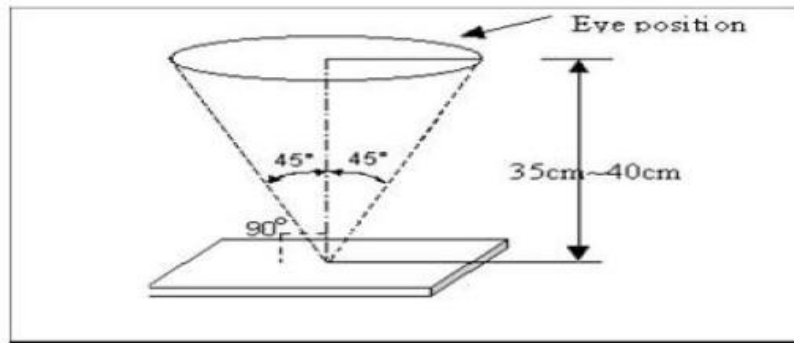

### 11.5 Inspection Criteria

Defects are classified as major defects and minor defects according to the degree of Defectiveness defined herein.



#### 11.5.1 Major defect

Item No	Items to be inspected	Inspection Standard
5.1.1	All functional defects	1) No display 2) Display abnormally 3) Short circuit 4) line defect
5.1.2	Missing	Missing function component
5.1.3	Crack	Glass Crack

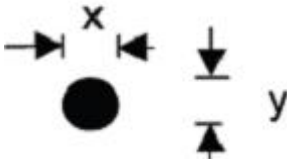
#### 11.5.2 Minor defect

Item No	Items to be inspected	Inspection standard	
5.2.1	Spot Defect Including Black spot White spot Pinhole Foreign particle Polarizer dirt	For dark/white spot is defined $\phi = (x+y) / 2$ 	
		Size $\phi$ (mm)	Acceptable Quantity
		$\phi \leq 0.2$	Ignore
		$0.2 < \phi \leq 0.5$	3
		$0.5 < \phi$	Not allowed

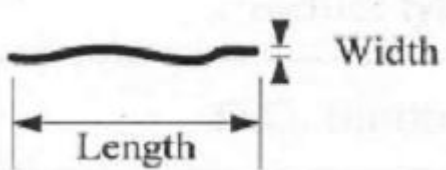

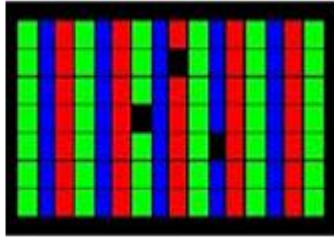
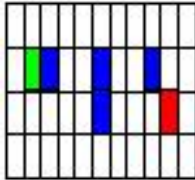
5.2.2	Line Defect Including Black line White line Scratch	Define: 			
		Width(mm) Length(mm)		Acceptable Quantity	
		$W \leq 0.05$		Ignore	
		$0.05 < W \leq 0.1$ $L \leq 2.5$		3	
		$0.1 < W$ , or $L > 2.5$		Not allowed	
5.2.3	Polarizer Dent/Bubble	Size $\phi$ (mm)		Acceptable Quantity	
		$\phi \leq 0.2$		Ignore	
		$0.2 < \phi \leq 0.3$		2	
		$0.3 < \phi \leq 0.5$		1	
		$0.5 < \phi$		Not allowed	
		Total QTY		3	
5.2.4	Electrical Dot Defect	Bright and Black dot define:  and 			
		 Two Adjacent Dot			
		Inspection pattern: Full white, Full black, Red, green and blue screens			
		Item	Acceptable Quantity		
			I	O	Note
		Black dot defect	2		$\phi \leq 0.15$ (5mm $\leq$ Distance)
		Bright dot defect	1		
Total Dot	1				

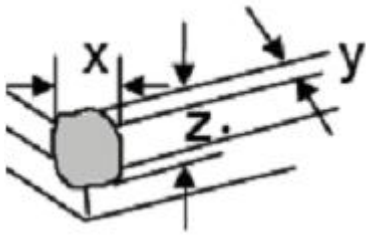
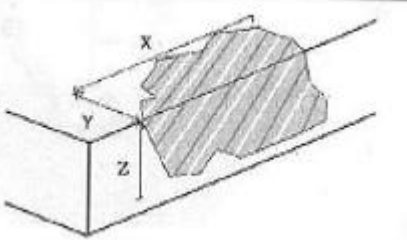
5.2.5	Glass defect		
		<b>1. Corner Fragment:</b>	
		<b>Size(mm)</b>	<b>Acceptable Quantity</b>
		$X \leq 3\text{mm}$ $Y \leq 1\text{mm}$ $Z \leq T$	Ignore T: Glass thickness X: Length Y: Width Z: thickness
		<b>2. Side Fragment:</b>	
			
<b>Size(mm)</b>		<b>Acceptable Quantity</b>	
$X \leq 5.0\text{mm}$ $Y \leq 1\text{mm}$ $Z \leq T$		T: Glass thickness X: Length Y: Width Z: thickness	

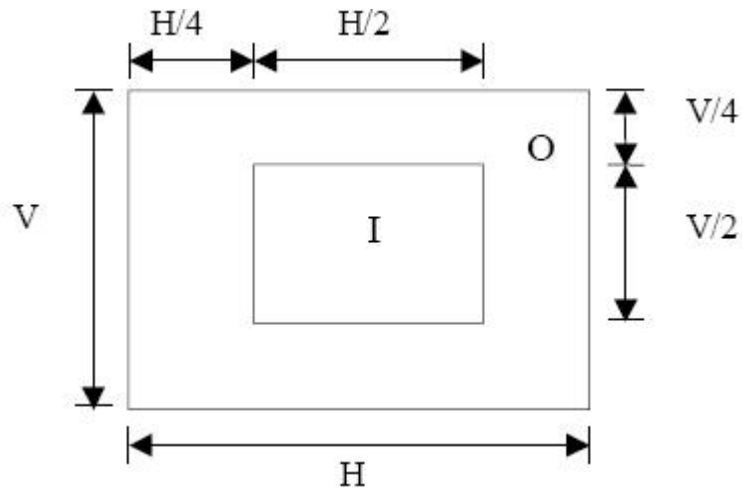

### I area & O area

- Note:
- 1). Dot defect is defined as the defective area of the dot area is larger than 50% of the dot area.
  - 2). The distance between two bright dot defects (red, green, blue, and white) should be larger than 15mm.
  - 3). The distance between black dot defects or black and bright dot defects should be more than 5mm apart.
  - 4). Polarizer bubble is defined as the bubble appears on active display area. The defect of polarizer bubble shall be ignored if the polarizer bubble appears on the outside of active display area.

### 11.6 Mechanics specification

As for the outside dimension, weight of the modules, please refer to product specification  
For more details

## 12. Precautions for Use of LCD modules

### 12.1 Handling Precautions

12.1.1. The display panel is made of glass. Do not subject it to a mechanical shock by dropping it from a high place, etc.

12.1.2. If the display panel is damaged and the liquid crystal substance inside it leaks out, be sure not to get any in your mouth, if the substance comes into contact with your skin or clothes, promptly wash it off using soap and water.

12.1.3. Do not apply excessive force to the display surface or the adjoining areas since this may cause the color tone to vary.

12.1.4. The polarizer covering the display surface of the LCD module is soft and easily scratched. Handle this polarizer carefully.

12.1.5. If the display surface is contaminated, breathe on the surface and gently wipe it with a soft dry cloth. If still not completely clear, moisten cloth with one of the following solvents:

- Isopropyl alcohol
- Ethyl alcohol

Solvents other than those mentioned above may damage the polarizer. Especially, do not use the following:

- Water
- Ketene
- Aromatic solvents

12.1.6. Do not attempt to disassemble the LCD Module.

12.1.7. If the logic circuit power is off, do not apply the input signals.

12.1.8. To prevent destruction of the elements by static electricity, be careful to maintain an optimum work environment.

12.1.8.1. Be sure to ground the body when handling the LCD Modules.

12.1.8.2. Tools required for assembly, such as soldering irons, must be properly ground.

12.1.8.3. To reduce the amount of static electricity generated, do not conduct assembly and other work under dry conditions.

12.1.8.4. The LCD Module is coated with a film to protect the display surface. Be care when peeling off this protective film since static electricity may be generated.

### 12.2 Storage Precautions

12.2.1. When storing the LCD modules, avoid exposure to direct sunlight or to the light of fluorescent lamps.

12.2.2. The LCD modules should be stored under the storage temperature range. If the LCD modules will be stored for a long time, the recommend condition is:

Temperature : 0°C ~ 40°C      Relatively humidity: ≤80%

12.2.3. The LCD modules should be stored in the room without acid, alkali and harmful gas.

### **12.3 Transportation Precautions**

The LCD modules should be no falling and violent shocking during transportation, and also should avoid excessive press, water, damp and sunshine.